

TECHNICAL MANUAL

**ORGANIZATIONAL, DIRECT SUPPORT,
AND GENERAL SUPPORT MAINTENANCE
REPAIR PARTS AND SPECIAL TOOLS LIST**

FOR

**SPRAYER, INSECTICIDE, AIRCRAFT-MOUNTED:
WITH PUMP, 195 GALLONS CAPACITY,
GED (AGRINAUTICS MODEL NO. 30000)
NSN 3740-00-470-9811**

This manual supersedes TM 5-3740-211-24P, 6 November 1972, including all changes.

**HEADQUARTERS, DEPARTMENT OF THE ARMY
26 NOVEMBER 1979**

CHANGE HEADQUARTERS
No. 1 DEPARTMENT OF THE ARMY
WASHINGTON, D.C., 16 September 1987

Organizational, Direct Support, and General Support Maintenance
Repair Parts and Special Tools List

for

SPRAYER, INSECTICIDE, AIRCRAFT-MOUNTED:
WITH PUMP, 195 GALLONS CAPACITY,
GED (AGRINAUTICS MODEL NO. 30000)
NSN 3740-00-470-9811

TM 5-3740-211-24P, 26 November 1979, is changed as follows:

1. Remove and insert pages as indicated below. New or changed text material is indicated by a vertical bar in the margin. An illustration change is indicated by a miniature pointing hand.

Remove pages	Insert pages
i and ii 7 and 8	i and ii 7 and 8

2. Retain this sheet in front of manual for reference purposes.

By Order of the Secretary of the Army:

CARL E. VUONO
General, United States Army
Chief of Staff

Official:

R. L. DILWORTH
Brigadier General, United States Army
The Adjutant General

DISTRIBUTION:

To be distributed in accordance with DA Form 12-25A, Unit, Direct Support and General Support Maintenance requirements for Sprayer, Insecticide, Aircraft Mounted, with Pump, Model 30000, 195 GAL Capacity.

**ORGANIZATIONAL, DIRECT SUPPORT AND
GENERAL SUPPORT MAINTENANCE
REPAIR PARTS AND SPECIAL TOOLS LIST**

FOR

**SPRAYER, INSECTICIDE, AIRCRAFT-MOUNTED: WITH PUMP,
195 GALLONS CAPACITY, GED (AGRINAUTICS MODEL
NO. 30000)
NSN 3740-00-470-9811**

Current as of 8 October 1979

REPORTING ERRORS AND RECOMMENDING IMPROVEMENTS

You can help improve this manual. If you find any mistake or if you know of a way to improve the procedures, please let us know. Mail your letter, DA Form 2028 (Recommended Changes to Publications and Blank Forms), or DA Form 2028-2 located in the back of this manual direct to: Commander, U.S. Army Troop Support Command, ATTN: AMSTR-MCTS, 4300 Goodfellow Boulevard, St. Louis, MO 63120-1798. A reply will be furnished directly to you.

Table of Contents

	Page	Illus Figure
SECTION I. INTRODUCTION	1	
SECTION II. REPAIR PARTS LIST	7	
Group 01. Sprayer Assembly Tank and Related Parts	7	
Sprayer Assembly	6	1
Sprayer Tank	8	2
Sprayer Assembly, Related Parts	10	3
Sprayer Assembly, Tank and Related Parts	12	4
02. Sprayer Manual Control and Valve Assembly	15	
Sprayer Manual Control	14	5
Sprayer Control Valve Assembly	16	6
Sprayer Manual Control and Valve Assembly	18	7
03. Sprayer Pump and Brake Assembly.....	21	
Sprayer Pump and Brake Assembly.....	20	8
04. Sprayer Pump Assembly	23	
Sprayer Pump Assembly	22	9
05. Sprayer Synchromatic Windmill Assembly.....	25	
Sprayer Synchromatic Windmill Assembly	24	10
06. Sprayer Boom Assembly	27	
Sprayer Boom Assembly	26	11
Boom Assembly	28	12
07. Sprayer Nozzle Assembly.....	31	
Sprayer Nozzle Assembly	30	13
08. Sprayer Skid and Shipping Parts	33	
Sprayer Skid and Shipping Parts	32	14
09. Liquid Loading System	35	
Liquid Loading System	34	15

	Page	Illus Figure
10. Liquid Loading System Pump Engine	37	
Fuel and Oil Tank	36	16
Liquid Loading System	38	17
11. Liquid Loading System Engine Carburetor Chamber.....	41	
Liquid Loading System Engine Carburetor Chamber	40	18
Engine Carburetor Chamber	42	19
12. Liquid Loading System Pump Starter Fan Housing and Ignition Parts...	45	
Liquid Loading System Fan Housing	44	20
Liquid Loading System Pump Starter and Ignition Parts.....	46	21
13. Liquid Loading System Pump	49	
Liquid Loading System Pump	48	22
Liquid Loading System Pump	50	23
14. Liquid Loading System Ball Valve.....	53	
Liquid Loading System Ball Valve.....	52	24
15. Liquid Loading System Strainer	55	
Liquid Loading System Strainer	54	25
SECTION III. SPECIAL TOOLS LIST (Not Applicable)		
SECTION IV. NATIONAL STOCK NUMBER AND REFERENCE NUMBER INDEX.....	57	

Section I. INTRODUCTION

1. Scope.

This Manual lists spares and repair parts; special tools; special test, measurement, and diagnostic equipment (TMDE), and other special support equipment required for performance of organizational, direct support, and general support maintenance of the Sprayer. It authorizes the requisitioning and issue of spares and repair parts as indicated by the source and maintenance codes.

2. General.

This Repair Parts and Special Tools List is divided into the following sections:

a. Section II Repair Parts List. A list of spares and repair parts authorized for use in the performance of maintenance. The list also includes parts which must be removed for replacement of the authorized parts. Parts lists are composed of functional groups ascending in numeric sequence, with the parts in each group listed in figure and item number sequence. Bulk materials are listed in NSN sequence.

b. Section III Special Tools List. A list of special tools, special TMDE, and other special support equipment authorized for the performance of maintenance.

c. Section IV National Stock Number and Part Number Index. A list, in National item identification number (NIIN) sequence, of all National stock numbers (NSNO) appearing in the listings, followed by a list, in alphameric sequence of all part numbers appearing in the listings. National stock number and part numbers are cross-referenced to each illustration figure and item number appearance. This index is followed by a cross-reference list of reference designators to figure and item numbers.

3. Explanation of Columns.

a. Illustration. This column is divided as follows:

(1) Figure Number. Indicates the figure number of the illustration in which the item is shown.

(2) Item Number. The number used to identify item called out in the illustration.

b. Source, Maintenance, and Recoverability (SMR) Codes.

(1) Source Code. Source codes indicate the

manner of acquiring support items for maintenance, repair, or overhaul of end items. Source codes are entered in the first and second positions of the Uniform SMR Code format as follows:

Code	Definition
PA	Item procured and stocked for anticipated or known usage.
PB	Item procured and stocked for insurance purposes because essentiality dictates that a minimum quantity be available in the supply systems.
PC	Item procured and stocked and which otherwise would be coded PA except that it is deteriorative in nature.
PD	Support item, excluding support equipment, procured for initial issue or outfitting and stocked only for subsequent or additional initial issues or outfitting. Not subject to automatic replenishment.
PE	Support equipment procured and stocked for initial issue or outfitting to specified maintenance repair activities.
PF	Support equipment which will not be stocked but which will be centrally procured on demand.
PG	Item procured and stocked to provide for sustained support for the life of the equipment. It is applied to an item peculiar to the equipment which, because of probable discontinuance or shutdown of production facilities, would prove uneconomical to reproduce at a later time.
KD	An item of a depot overhaul/repair kit and not purchased separately. Depot kit defined as a kit that provides items required at the time of overhaul or repair.
KF	An item of a maintenance kit and not purchased separately. Maintenance kit defined as a kit that provides an item that can be replaced at organizational or intermediate levels of maintenance.
KB	Item included in both a depot overhaul/repair kit and a maintenance kit.
MO	Item to be manufactured or fabricated at organizational level.
MF	Item to be manufactured or fabricated at the direct support maintenance level.
MH	Item to be manufactured or fabricated at

- the general support maintenance level.
- MD** Item to be manufactured or fabricated at the depot support maintenance level.
- AO** Item to be assembled at organizational level.
- AF** Item to be assembled at direct support maintenance level.
- AH** Item to be assembled at general support maintenance level.
- AD** Item to be assembled at depot maintenance level.
- XA** Item is not procured or stocked because the requirements for the item will result in the replacement of the next higher assembly.
- XB** Item is not procured or stocked. If not available through salvage, requisition.
- XC** Installation drawing, diagram, instruction sheet, field service drawing, that is identified by manufacturer's part number.
- XD** A support item that is not stocked. When required, item will be procured through normal supply channels.

NOTE

Cannibalization or salvage may be used as a source of supply for any items source coded above except those coded XA and aircraft support items as restricted by AR 700-42.

(2) Maintenance Code. Maintenance codes are assigned to indicate the levels of maintenance authorized to USE and REPAIR support items. The maintenance codes are entered in the third and fourth positions of the Uniform SMR Code format as follows:

(a) The maintenance code entered in the third position will indicate the lowest maintenance level authorized to remove, replace, and use the support item. The maintenance code entered in the third position will indicate one of the following levels of maintenance:

Code	Application/Explanation
C	Crew or operator maintenance performed within organizational maintenance.
O	Support item is removed, replaced, used at the organizational level.
F	Support item is removed, replaced, used at the direct support level.
H	Support item is removed, replaced, used at

- the general support level.
- D** Support items that are removed, replaced, used at depot, mobile depot, specialized repair activity only.

(b) The maintenance code entered in the fourth position indicates whether the item is to be repaired and identifies the lowest maintenance level with the capability to perform complete repair (i.e., all authorized maintenance functions). This position will contain one of the following maintenance codes:

Code	Application/Explanation
O	The lowest maintenance level capable of complete repair of the support item is the organizational level.
F	The lowest maintenance level capable of complete repair of the support item is the direct support level.
H	The lowest maintenance level capable of complete repair of the support item is the general support level.
D	The lowest maintenance level capable of complete repair of the support item is the depot level.
L	Repair restricted to designated Specialized Repair Activity.
Z	Nonrepairable. No repair is authorized.
B	No repair is authorized. The item may be reconditioned by adjusting, lubricating, etc., at the user level. No parts or special tools are procured for the maintenance of this item.

(3) Recoverability Code. Recoverability codes are assigned to support items to indicate the disposition action on unserviceable items. The recoverability code is entered in the fifth position of the Uniform SMR Code format as follows:

Recoverability Codes	Definition
Z	Nonreparable item. When unserviceable, condemn and dispose at the level indicated in position 3.
O	Reparable item. When uneconomically repairable, condemn and dispose at organizational level.
F	Reparable item. When uneconomically

reparable, condemn and dispose at the direct support level.

- H** Reparable item. When uneconomically reparable, condemn and dispose at the general support level.
- D** Reparable item. When beyond lower level repair capability, return to depot. Condemnation and disposal not authorized below depot level.
- L** Reparable item. Repair, condemnation, and disposal not authorized below depot/specialized repair activity level.
- A** Item requires special handling or condemnation procedures because of specific reasons (i.e., precious metal content, high dollar value, critical material or hazardous material). Refer to appropriate manuals/directives for specific instructions.

c. National Stock Number. Indicates the National stock number assigned to the item and will be used for requisitioning purposes.

d. Part Number. Indicates the primary number used by the manufacturer which controls the design and characteristics of the item by means of its engineering drawings, specifications, standards, and inspection requirements to identify an item or range of items.

NOTE

When a stock numbered item is requisitioned, the repair part received may have a different part number than the part being replaced.

e. Federal Supply Code for Manufacturer (FSCM). The FSCM is a 5-digit numeric code listed in SB 708-42 which is used to identify the manufacturer, distributor, or Government agency, etc.

f. Description. Indicates the Federal item name and, if required, a minimum description to identify the item. Items that are included in kits and sets are listed below the name of the kit or set with the quantity of each item in the kit or set indicated in the quantity incorporated in unit column. When the part to be used differs between serial numbers of the same model, the effective serial numbers are shown as the last line of the description. In the Special Tools List, the initial basis of issue (BOI) appears as the last line in the entry for each special tool, TMDE, and support equipment. When density of equipments supported exceeds density spread indicated in the basis of issue, the total authorization is increased accordingly.

g. Unit of Measure (U/M). Indicates the standard of the basic quantity of the listed item as used in performing the actual maintenance function. This measure is expressed by a two-character alphabetical abbreviation (e.g., ea, in., pr, etc.). When the unit of measure differs from the unit of issue, the lowest unit of issue that will satisfy the required units of measure will be requisitioned.

h. Quantity Incorporated in Unit. Indicates the quantity of the item used in the breakout shown on the illustration figure, which is prepared for a functional group, subfunctional group, or an assembly. A "V" appearing in this column in lieu of a quantity indicates that no specific quantity is applicable (e.g., shims, spacers, etc.).

4. Special Information.

a. Repair parts kits and gasket sets appear as the last entries in the repair parts listing for the figure in which its parts are listed as repair parts or are listed at the end of the repair parts listing for the last figure containing parts of the kit.

b. The following publications pertain to the sprayer and its components.
 TM 5-3740-211-14 Operator, Organizational, Direct Support and General Support Maintenance Manual.

5. How to Locate Repair Parts.

a. When National Stock Number or Part Number is Unknown:

(1) First. Using the table of contents, determine the functional group within which the repair part belongs. This is necessary since illustrations are prepared for functional groups, and listings are divided into the same groups.

(2) Second. Find the illustration covering the functional group to which the item belongs.

(3) Third. Identify the item on the illustration and note the illustration figure and item number of the repair part.

(4) Fourth. Using the Repair Parts Listing, find the figure and item number noted on the illustration.

b. When National Stock Number or Part Number is Known.

(1) First. Using the Index of National Stock

Numbers and Part Numbers, find the pertinent National stock number or part number. This index is in NIIN sequence followed by a list of part numbers in alphameric sequence, cross-referenced to the illustration figure number and item number.

(2) Second. After finding the figure and item number, locate the figure and item number in the repair parts list.

6. Abbreviations.

Abbreviations	Explanation
AL	Aluminum
ASSY	Assembly
DIA	Diameter
ID	Inside Diameter
IN	Inch
LB	Pound
EA	Each
FIG	Figure
FT	Foot
NO	Number
OD	Outside Diameter
SMR	Source, Maintenance and Recoverability
U/M	Unit of Measure

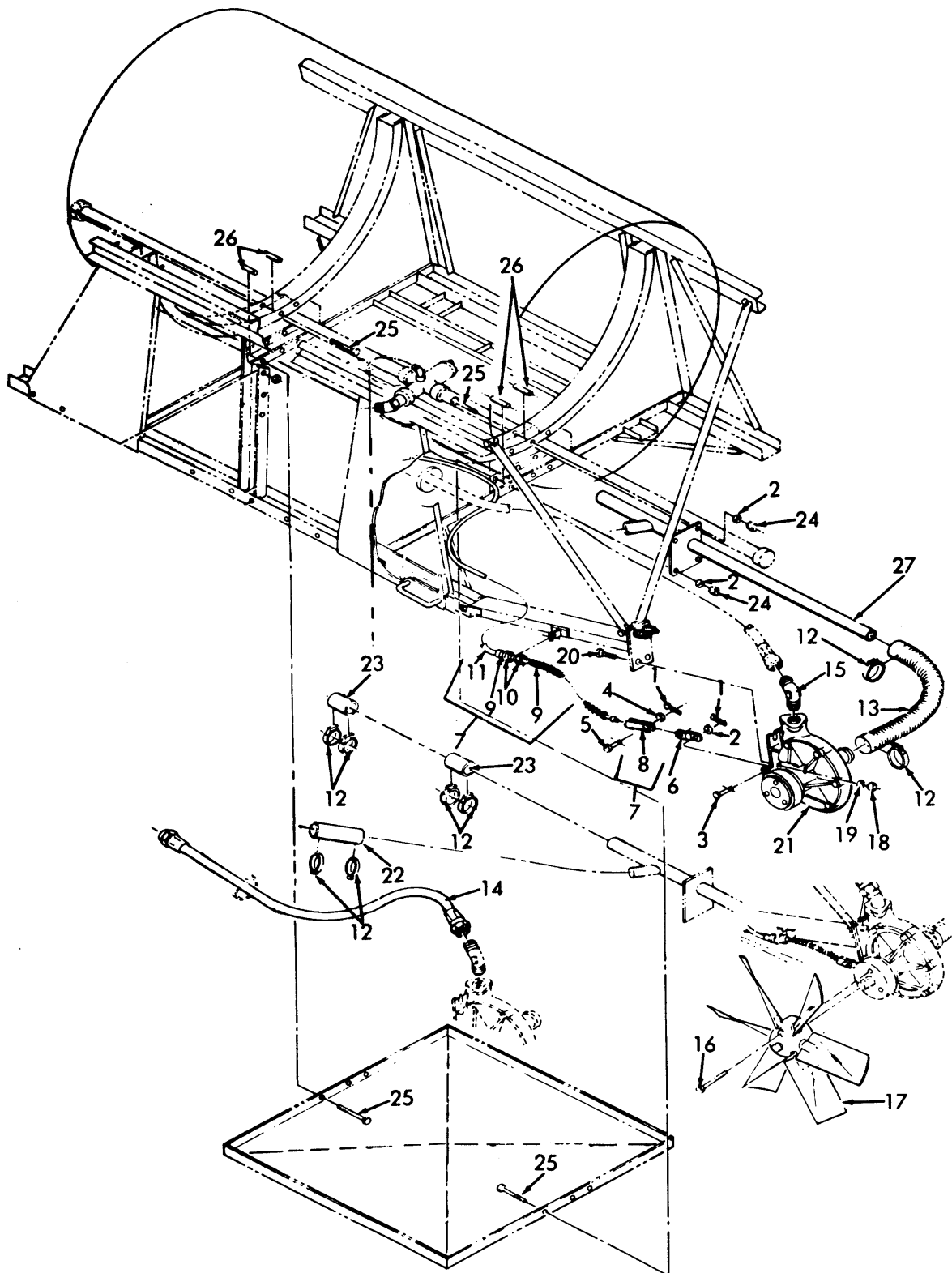

TS 3740-211-24P/1

Figure 1. Sprayer Assembly.

(1) ILLUSTRATION		(2)	(3)	(4)	(5)	(6)	(7)	(8)
(a) FIG NO.	(b) ITEM NO.	SMR CODE	NATIONAL STOCK NUMBER	PART NUMBER	FSCM	DESCRIPTION USABLE ON CODE	U/M	QTY INC IN UNIT
						SECTION 11. REPAIR PARTS LIST GROUP 01 - SPRAYER ASSEMBLY TANK AND RELATED PARTS		
1	1	PAOZZ	5315-00-815-1405	Ms24665-151	96906	PIN, COTTER.....	EA	2
1	2	PAOZZ	5310-00-582-5677	Ms15795-810	96906	WASHER, FLAT	EA	2
1	3	PAOZZ	5315-00-488-6290	MS89464-14	96906	PIN, CLEVIS.....	EA	1
1	4	PAOZZ	5310-00-619-1148	MS15795-808	96906	WASHER, FLAT	EA	1
1	5	PAOZZ	5315-00-811-1241	MS2039202C17	96906	PIN, STRAIGHT, HEADED	EA	1
1	6	PAOZZ	3740-00-179-6684	3049	22065	LINK PUMP TO CABLE	EA	2
1	7	XBOZZ		30397	22065	CABLE ASSEMBLY PUMP TO MANUAL CONTROL.....	EA	1
1	8	PAOZZ	3740-00-179-6683	6011	22065	FORK PUMP CABLE	EA	1
1	9	PAOZZ	5310-00-579-0848	AN316-6	88044	.NUT, JAM.....	EA	2
1	10	PAOZZ	5310-00-080-6004	MS27183-14	96906	.WASHER, FLAT	EA	2
1	11	XBOZZ		YA14-244D	92867	.CABLE PUMP BRAKE TO MANUAL CONTROL	EA	1
1	12	PAOZZ	4730-00-909-8627	MS35842-13	96906	CLAMP, HOSE LOW PRESSURE	EA	10
1	13	XBOZZ		30307-5	22065	HOSE, RUBBER PUMP TO TUBE	EA	1
1	14	PAOZZ	4720-00-541-9266	MS28741-20-0520	96906	-HOSE, RUBBER.....	EA	1
1	15	PAOZZ	4730-00-764-7857	MS20823-20D	96906	ELBOW, PIPE TO TUBE	EA	1
1	16	XBOZZ		1019	22065	SCREW ASSEMBLY	EA	3
1	17	PAOZZ	3740-00-179-6704	6645	22065	PARTS KIT, WINDMILL.....	EA	1
1	18	PAOZZ	5310-00-857-4959	MS21044C6	96906	NUT, SELF-LOCKING	EA	2
1	19	PAOZZ	5310-00-773-7618	MS15795-814	96906	WASHER, FLAT	EA	2
1	20	PAOZZ	5305-00-685-3509	MS35308-362	96906	SCREW, CAP, HEXAGON HEAD	EA	2
1	21	PAOZZ	3740-00-403-5239	6330-1	22065	PUMP AND BRAKE ASSEMBLY SPRAYER .	EA	1
1	22	XBOZZ		3082-3	22065	HOSE, RUBBERVALVE TO PUMP, FLEXIBLE	RA	1
1	23	MOOZZ		30307-3	22065	HOSE, RUBBER VALVE, FLEXIBLE.....	EA	2
1	24	PAOZZ	5310-00-889-2589	MS21044C4	96906	NUT, SELF-LOCKING	EA	4
1	25	PAOZZ	5305-00-720-8247	MS35308-319	96906	SCREW, CAP, REXAGON HEAD	EA	12
1	26	XBOZZ		30369	22065	SPACER.....	EA	12
1	27	XBOZZ		30304	22065	TUBE PUMP INLET	EA	1

Change 1 7

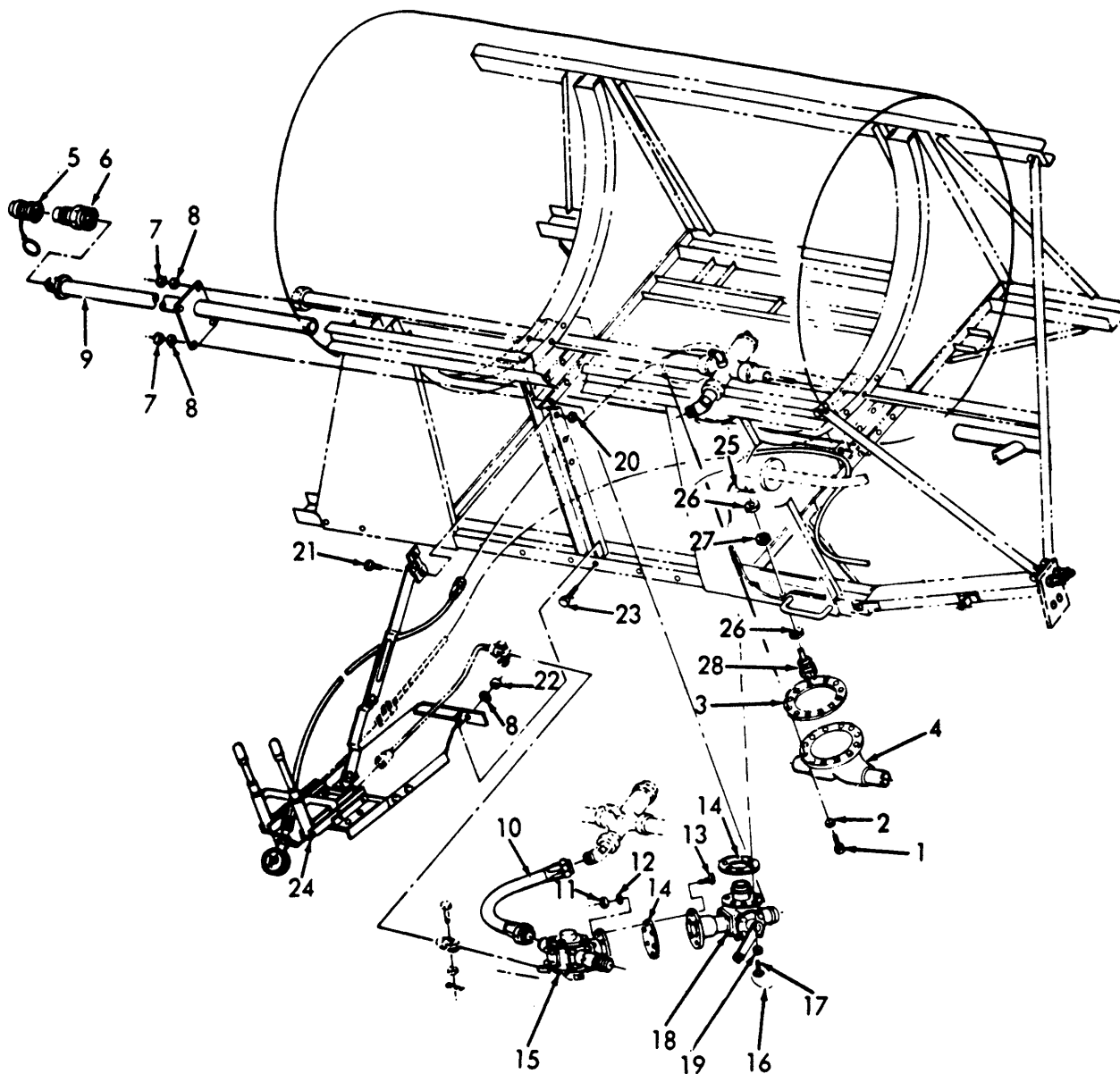

TS 3740-211-24P/2

Figure 2. Sprayer Tank.

*U.S. Government Printing Office: 1987-754-030/60480

PIN: 0054531/N 001

SECTION II

TM 5-3740-211-24P

(1) ILLUSTRATION		(2)	(3)	(4)	(5)	(6)	(7)	(8)
(a) FIG NO.	(b) ITEM NO.	SMR CODE	NATIONAL STOCK NUMBER	PART NUMBER	FSCM	DESCRIPTION USABLE ON CODE	U/M	QTY INC IN UNIT
2	1	PAFZZ	5305-00-059-3662	MS51958-66	96906	SCREW, MACHINE SUMP MOUNTING	EA	12
2	2	XBFZZ		1017-187-032	22065	WASHER, LOCK SUMP MOUNTING.....	EA	12
2	3	XBFZZ		3043	22065	GASKET SUMP	EA	1
2	4	XBFZZ		3033	22065	SUMP	EA	1
2	5	XBOZZ		ADCK24	78357	CAP, DUST COUPLER.....	EA	1
2	6	XBOZZ		AVKN24-24FTEF	78357	COUPLER VALVE	EA	1
2	7	PAOZZ	5310-00-889-2589	MS21044C4	96906	NUT, SELF-LOCKING	EA	4
2	8	PAOZZ	5310-00-582-5677	MS15795-810	96906	WASHER, FLAT	EA	6
2	9	XBOZZ		30398	22065	TUBE GROUND LOADING.....	EA	1
2	10	PAOZZ	4720-00-762-1420	MS28741-20-0140	96906	HOSE ASSEMBLY VALVE TO CENTER BOOM	EA	1
2	11	XBOZZ		MS20365-1032	96906	NUT, PLAIN, HEXAGON. VALVE ASSEMBLY MOUNTING	EA	6
2	12	PAOZZ	5310-00-167-0818	AN960-10	88044	WASHER, FLATVALVE ASSEMBLY MOUNTING	EA	6
2	13	PAOZZ	5306-00-656-0358	AN3-6A	88044	BOLT, MACHINEVALVE ASSEMBLY MOUNTING	EA	6
2	14	KFOZZ	5330-00-179-6246	7407	22065	GASKET VALVE PART OF KIT P/N K7520-1	EA	2
2	15	XBOZZ		7520-175427538	22065	VALVEASSEMBLY CONTROL	EA	1
2	16	PAOZZ	9505-00-603-4120	MS20995C41	96906	LOCKWIRE	LB	V
2	17	PAOZZ	5306-00-182-1853	AN3CH4A	88044	BOLT, MACHINE	EA	6
2	18	XBOZZ		7520-175696538-1	22065	VALVEASSEMBLY BY-PASS	EA	1
2	19	PAOZZ	5310-00-619-1148	MS15795-808	96906	WASHER, FLAT	EA	6
2	20	PAFZZ	5310-00-725-9488	MS35426-4	96906	NUT, PLAIN, WING	EA	8
2	21	PAFZZ	5305-00-688-2018	MS35308-307	96906	SCREW, CAP, HEXAGON HEAD	EA	8
2	22	PAFZZ	5310-00-889-2589	MS21044C4	96906	NUT, SELF-LOCKING	EA	2
2	23	PAFZZ	5305-00-720-8245	MS35308-309	96906	SCREW, CAP, HEXAGONHEAD	EA	2
2	24	XBFZZ		30310	22065	CONTROL, MANUAL.....	EA	1
2	25	PAOZZ	5315-00-234-1854	MS24665-153	96906	PIN, COTTER.....	EA	9
2	26	PAOZZ	5310-00-926-5913	MS35691-23	96906	NUT, PLAIN, HEXAGON.....	EA	9
2	27	PAOZZ	15310-00-614-3506	MS15795-817	96906	WASHER, FLAT	EA	18
2	28	XBOZZ		30352	22065	STUD FITTING.....	EA	9
2		XBFZZ		EPOCAST202-9615	99384	KIT HARDNER INSECTICIDE TANK REPAIR	GL	1
					9			

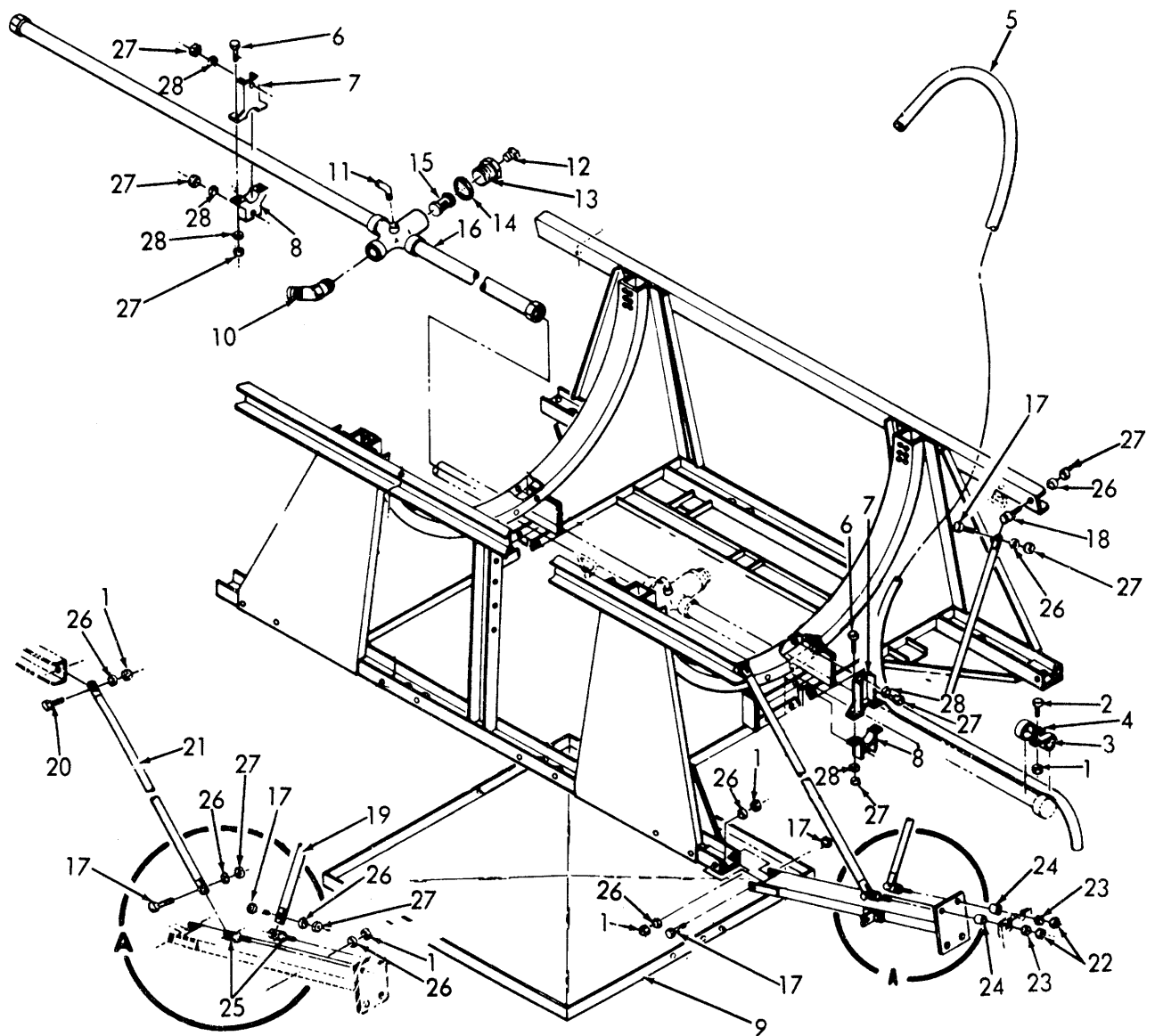

TS 3740-211-24P/3

Figure 3. Sprayer Assembly, Related Parts.

SECTION II

TM 5-3740-211-24P

(1) ILLUSTRATION		(2)	(3)	(4)	(5)	(6)	(7)	(8)
(a) FIG NO.	(b) ITEM NO.	SMR CODE	NATIONAL STOCK NUMBER	PART NUMBER	FSCM	DESCRIPTION USABLE ON CODE	U/M	QTY INC IN UNIT
3	1	PAOZZ	5310-00-208-9255	MS21044C3	96906	NUT, SELF-LOCKING	EA	29
3	2	PAOZZ	5305-00-059-3662	MS51958-66	96906	SCREW, MACHINE	EA	2
3	3	PAOZZ	5340-00-598-8874	MS21104D24	96906	CLAMP, LOOP TUBE MOUNTING	EA	1
3	4	PAOZZ	5340-00-186-3388	AN742D28	88044	CLAMP, LOOP TUBE MOUNTING	EA	1
3	5	XBOZZ	4720-00-762-1650	3060-3	22065	TUBE OVERFLOW.....	EA	1
3	6	PAOZZ	5305-00-720-8245	MS35308-309	96906	SCREW, CAP, HEXAGON HEAD	EA	4
3	7	XBOZZ		3048-1	22065	CLAMP UPPER	EA	2
3	8	XBOZZ		3048-3	22065	CLAMP LOWER	EA	2
3	9	XBOZZ		3077	22065	PAN DRIP	EA	1
3	10	PAOZZ	4730-00-004-2243	MS20823-21D	96906	ELBOW, PIPE TO TUBE	EA	1
3	11	PAOZZ	4730-00-865-6597	SAEJ514	81343	ELBOW, PIPE TO TUBE	EA	1
3	12	XBOZZ		8400-1-2	22065	PLUG CENTER BOOM CAP.....	EA	1
3	13	XBOZZ		4123	22065	CAP CENTER BOOM	EA	1
3	14	XBOZZ	5330-00-769-2868	4122	22065	GASKET CENTER BOOM CAP	EA	1
3	15	XBOZZ		4121-16	22065	SCREEN ASSEMBLY CENTER BOOM.....	EA	1
3	16	XBOZZ		30204	22065	BOOM, CENTER	EA	1
3	17	PAOZZ	5306-00-156-2329	AN3C10A	88044	BOLT, MACHINE	EA	5
3	18	PAOZZ	5306-00-613-9038	AN43BC4A	88044	BOLT, EYE	EA	1
3	19	XBOZZ		30297	22065	STRUT PUMP, LONG.....	EA	1
3	20	PAOZZ	5306-00-156-2327	AN3C6A	88044	ROLT, MACHINE STRUT MOUNTING.....	EA	1
3	21	XBOZZ		30298	22065	STRUT PUMP, SHORT	EA	1
3	22	PAOZZ	5310-00-059-9265	MS21046C4	96906	NUT, SELF-LOCKING	EA	2
3	23	PAOZZ	5310-00-167-0766	AN970-4	88044	WASHER, FLAT	EA	2
3	24	XBOZZ		NAS75-4-010	00756	BUSHING, SLEEVE PUMP SUPPORT	EA	2
3	25	PAOZZ	5306-00-819-9674	AN43BC10A	88044	BOLT, EYE	EA	2
3	26	PAOZZ	5310-00-619-1148	MS15795-808	96906	WASHER, FLAT	EA	5
3	27	PAOZZ	5310-00-889-2589	MS21044C4	96906	NUT, SELF-LOCKING	EA	9
3	28	PAOZZ	5310-00-582-5677	MS15795-810	96906	WASHER, FLAT	EA	4
					11			

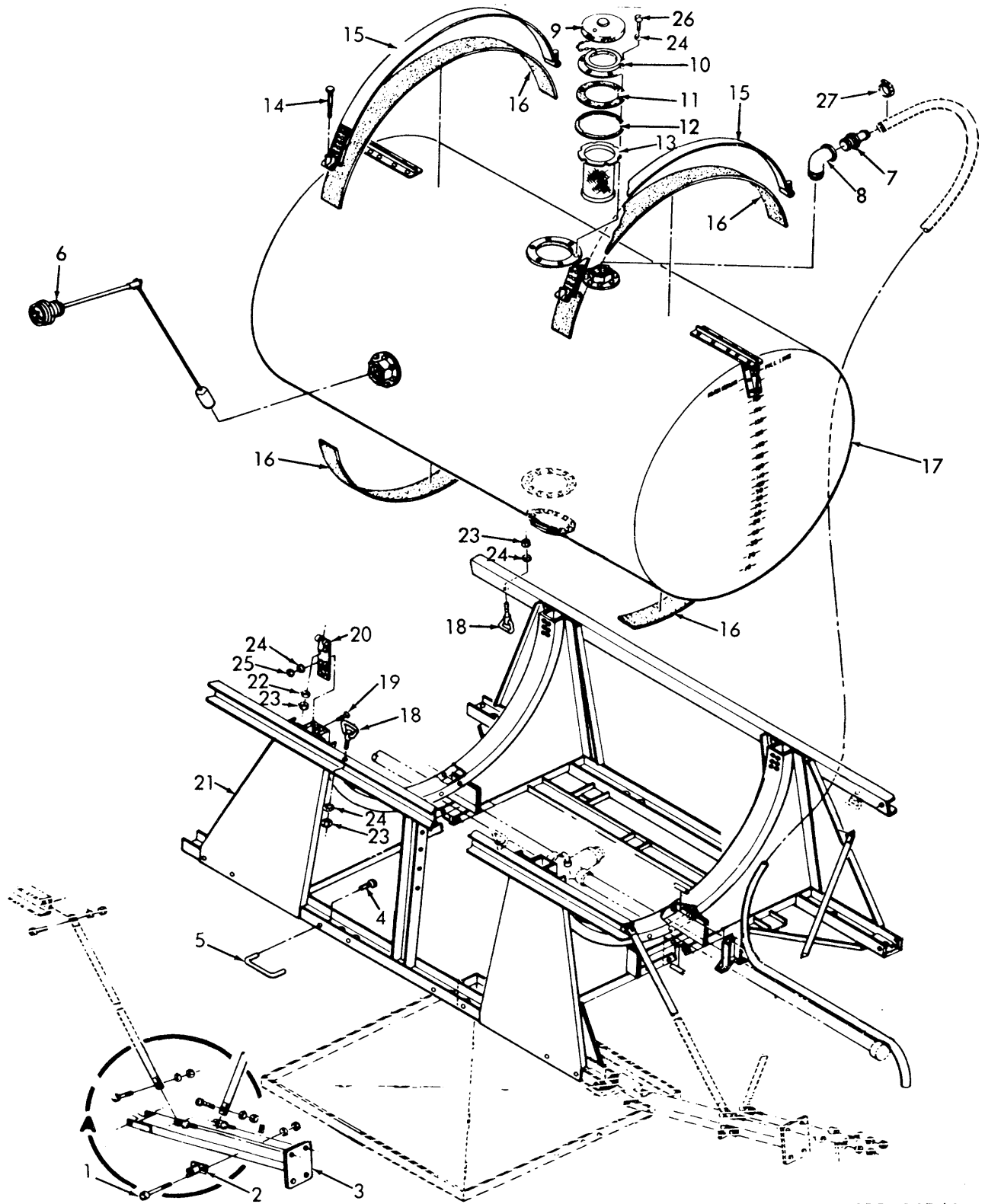

TS 3740-211-24P/4

Figure 4. Sprayer Assembly, Tank and Related Parts

SECTION II

TM 5-3740-211-24P

(1) ILLUSTRATION		(2)	(3)	(4)	(5)	(6)	(7)	(8)
(a) FIG NO.	(b) ITEM NO.	SMR CODE	NATIONAL STOCK NUMBER	PART NUMBER	FSCM	DESCRIPTION USABLE ON CODE	U/M	QTY INC IN UNIT
4	1	PAOZZ	5305-00-059-3671	MS51958-75	96906	SCREW, MACHINE	EA	2
4	2	XBOZZ		30303	22065	BRACKET STRUT	EA	1
4	3	XBOZZ		30302	22065	SUPPORT PUMP	EA	1
4	4	PAOZZ	5305-00-052-7004	MS21295-36	96906	SCREW, SELF-LOCKING	EA	16
4	5	XBOZZ		SS6	08730	HANDLE, LIFTING.....	EA	8
4	6	XBOZZ		3075	22065	GAGE, LIQUID LEVEL	EA	1
4	7	PAOZZ	4730-00-881-2220	MS24522-34	96906	ADAPTER, PIPE TO HOSE	EA	1
4	8	PAOZZ	4730-00-277-5546	MS51952-8	96906	ELBOW, PIPE STREET.....	EA	1
4	9	PAOZZ	2910-00-116-5243	MS53075-2	96906	CAP, TANK.....	EA	1
4	10	XBOZZ		ND1252	81118	FLANGE, TANK FILLER	EA	1
4	11	PAOZZ	5330-00-179-6679	3064	22065	GASKET FLANGE	EA	2
4	12	PAOZZ	5330-00-179-6703	3063	22065	FILLER, TANK.....	EA	1
4	13	PAOZZ	3740-00-179-6739	3068	22065	STRAINER, FUEL.....	EA	1
4	14	PAFZZ	5305-00-760-6889	MS35308-320	96906	SCREW, CAP, HEXAGON HEAD	EA	4
4	15	XBFZZ		3020	22065	STRAP ASSEMBLY TANK.....	EA	2
4	16	XBFZZ		3046	22065	CUSHION TANK STRAP	EA	4
4	17	XBFZZ		3062-9G	22065	TANK ASSEMBLY SPRAYER.....	EA	1
4	18	PAOZZ	4730-00-874-4083	NAS1211B15	80205	FITTING STRAP END TIEDOWN	EA	4
4	19	PAFZZ	5305-00-043-0267	MS24693C274	96906	SCREW, MACHINE	EA	24
4	20	XBFZZ		15361-10	98625	CLAMP TANK.....	EA	4
4	21	XBFZZ		30350	22065	SUPPORT TANK	EA	1
4	22	PAOZZ	5310-00-582-5677	MS15795-810	96906	WASHER, FLAT	EA	1
4	23	PAOZZ	5310-00-889-2589	MS21044C4	96906	NUT, SELF-LOCKING	EA	3
4	24	PAOZZ	5310-00-619-1148	MS15795-808	96906	WASHER, FLAT BRACKET MOUNTING	EA	9
4	25	PAOZZ	5310-00-208-9255	MS21044C3	96906	NUT, SELF-LOCKING	EA	1
4	26	PAOZZ	5305-00-059-3662	MS51958-66	96906	SCREW, MACHINE	EA	5
4	27	PAOZZ	4730-00-909-8627	MS35842-13	96906	CLAMP, HOSE LOW PRESSURE	EA	1
					13			

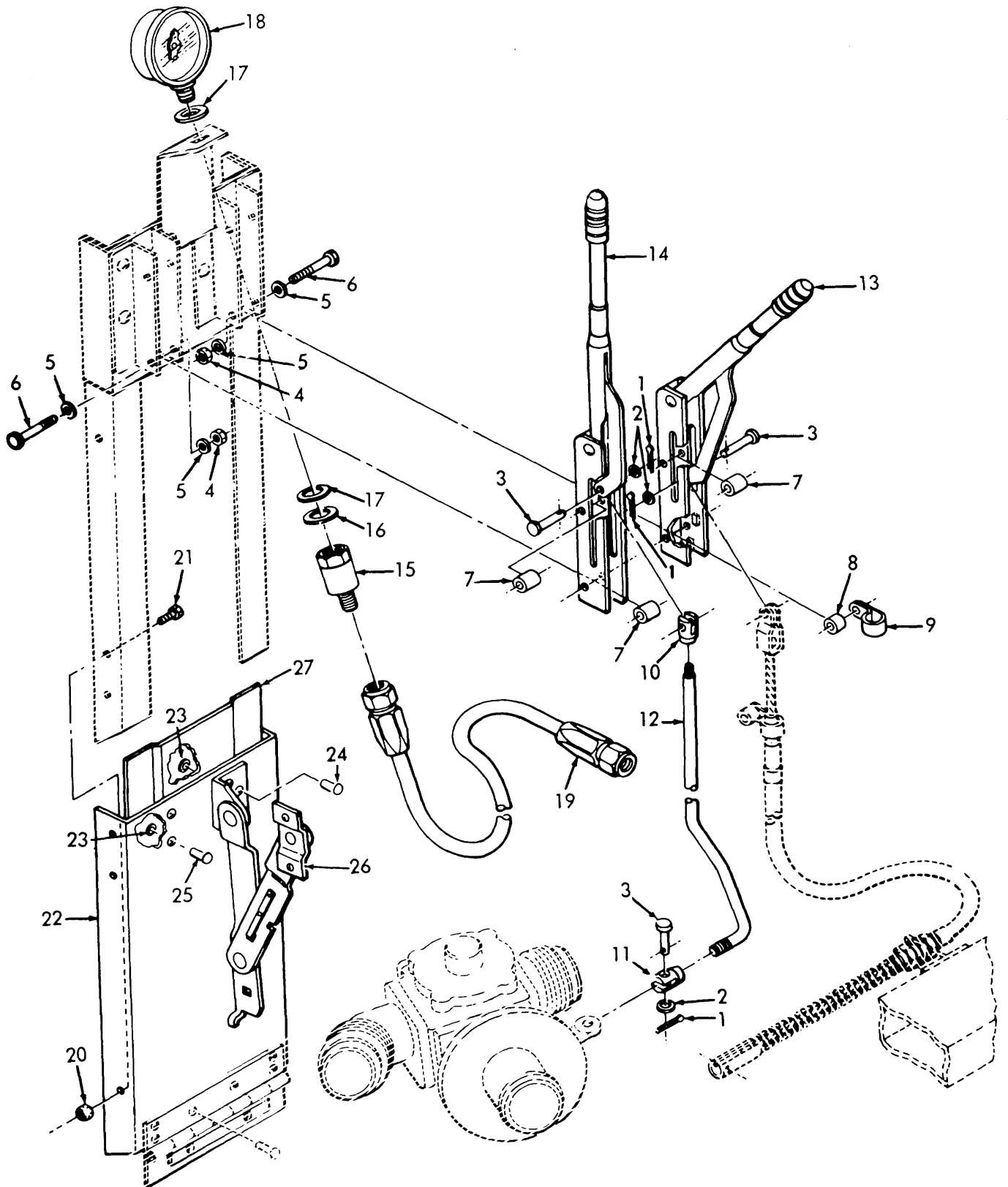

TS 3740-211-24P/5

Figure 5. Sprayer Manual Control.

SECTION II

TM 5-3740-211-24P

(1) ILLUSTRATION		(2)	(3)	(4)	(5)	(6) DESCRIPTION	(7)	(8)
(a) FIG NO.	(b) ITEM NO.	SMR CODE	NATIONAL STOCK NUMBER	PART NUMBER	FSCM	USABLE ON CODE	U/M	QTY INC IN UNIT
						GROUP 02 - SPRAYER MANUAL CONTROL AND VALVE ASSEMBLY		
5	1	PAOZZ	5315-00-815-1405	MS24665-151	96906	PIN, COTTER.....	EA	3
5	2	PAOZZ	5310-00-582-5677	MS15795-810	96906	WASHER, FLAT	EA	3
5	3	PAOZZ	5315-00-488-6290	MS9464-14	96906	PIN, CLEVIS.....	EA	3
5	4	XBOZZ		MS16228-2	96906	NUT, SELF-LOCKING	EA	2
5	5	PAOZZ	5310-00-625-5756	MS15795-812	96906	WASHER, FLAT	EA	4
5	6	PAOZZ	5306-00-724-5678	MS353-7-341	96906	BOLT, MACHINE	EA	2
5	7	XBOZZ		6008-17	22065	SPACER, SLEEVE HANDLE.....	EA	3
5	8	XBOZZ		6008-15	22065	SPACER, SLEEVE CLAMP.....	EA	1
5	9	XBOZZ		6008-13	22065	CLAMP, LOOP CABLE	EA	1
5	10	XBOZZ		30213-2	22065	CLEVIS LEVER VALVE ROD.....	EA	2
5	11	XBOZZ		30213-1	22065	CLEVIS LEVER VALVE ROD.....	EA	2
5	12	XBOZZ	3740-00-179-6686	3091-5	22065	ROD, VALVE HANDLE	EA	1
5	12	XBOZZ	3740-00-179-6687	3091-7	22065	ROD, VALVE HANDLE	EA	1
5	13	XBOZZ	2530-00-419-5816	01020306	92867	LEVER, BRAKE HAND	EA	1
5	14	XBOZZ		6008-3	22065	LEVER, VALVE HAND.....	EA	1
5	15	XBOZZ		SAEJ514FIG5C	81343	UNION HOSE TO GAGE	EA	1
5	16	PAOZZ	5310-00-922-1793	MS15795-843	96906	WASHER, FLAT UNION MOUNTING	EA	1
5	17	XBOZZ		2068	22065	WASHER, RUBBER UNION	EA	2
5	18	XDOZZ		P500	61349	GAGE, PRESSURE	EA	1
5	19	PAOZZ	4720-00-143-9264	MS28741-5-0720	96906	HOSE ASSEMBLY PRESSURE	EA	1
5	20	PAOZZ	5310-00-725-9488	MS35426-4	96906	NUT, PLAIN, WING SUPPORT MOUNTING.	EA	8
5	21	PAOZZ	5305-00-688-2018	MS35308-307	96906	SCREW, CAP, HEXAGON HEAD SUPPORT MOUNTING	EA	8
5	22	XBFZZ		30319	22065	SUPPORT MANUAL CONTROL	EA	1
5	23	XBFZZ		NAS1080D8	00756	.COLLAR BRACE	EA	5
5	24	XBFZZ		NAS1528-5	00756	.PIN, STRAIGHT, HEADED BRACE.....	EA	3
5	25	XBFZZ		NAS1528-3	00756	.PIN, STRAIGHT, HEADED GUIDE	EA	2
5	26	XAFZZ		13216E5318	97403	.BRACE MANUAL CONTROL.....	EA	1
5	27	XAFZZ		TYPE302304	97403	.GUIDE, SUPPORT SPRAYER.....	EA	1
					15			

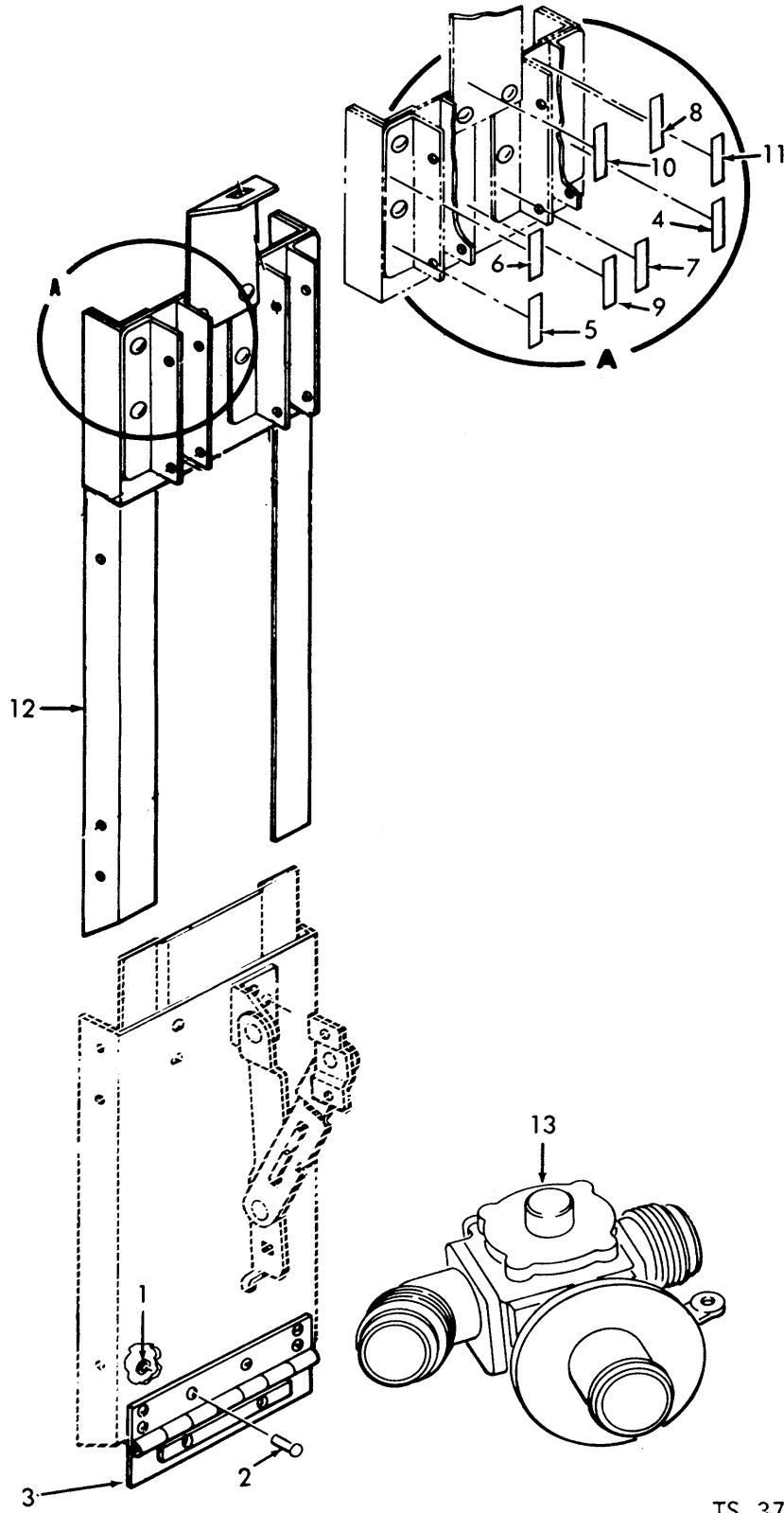

TS 3740-211-24P/6

Figure 6. Sprayer Control Valve Assembly.

SECTION II

TM 5-3740-211-24P

(1) ILLUSTRATION		(2)	(3)	(4)	(5)	(6)	(7)	(8)
(a) FIG NO.	(b) ITEM NO.	SMR CODE	NATIONAL STOCK NUMBER	PART NUMBER	FSCM	DESCRIPTION USABLE ON CODE	U/M	QTY INC IN UNIT
6	1	XBFZZ		NAS1080D6	00756	.COLLAR HINGE	EA	6
6	2	XBFZZ		NA81536-3	00756	.PIN, STRAIGHT, HEADED HINGE	EA	6
6	3	XBFZZ		MS35827-50	96906	.HINGE, MANUAL.....	EA	1
6	4	XBOZZ		30305-7	22065	PLATE, INSTRUCTION BRAKEOFF(ARROW LEFT)	EA	1
6	5	XBOZZ		30305-1	22065	PLATE, INSTRUCTION VALVE OPEN(ARROW RIGHT).....	EA	1
6	6	XBOZZ		30305-2	22065	PLATE, INSTRUCTION VALVE CLOSED(ARROW LEFT)	EA	1
6	7	XBOZZ		30305-3	22065	PLATE, ISNTRUCTION BRAKEOFF(ARROW RIGHT).....	EA	1
6	8	XBOZZ		30305-4	22065	PLATE, INSTRUCTION BRAKE ON(ARROW LEFT)	EA	1
6	9	XBOZZ		30305-5	22065	PLATE, INSTRUCTION VALVE OPEN(ARROW LEFT)	EA	1
6	10	XBOZZ		30305-6	22065	PLATE, INSTRUCTION VALVE CLOSED(ARROW RIGHT).....	EA	1
6	11	XBOZZ		30305-8	22065	PLATE, INSTRUCTION BRAKE ON(ARROW RIGHT).....	EA	1
6	12	XBPZZ		30355	22065	BRACKET, MANUAL	EA	1
6	13	XBFZZ		7550	22065	VALVE ASSEMBLY INSTALLATION.....	EA	1
					17			

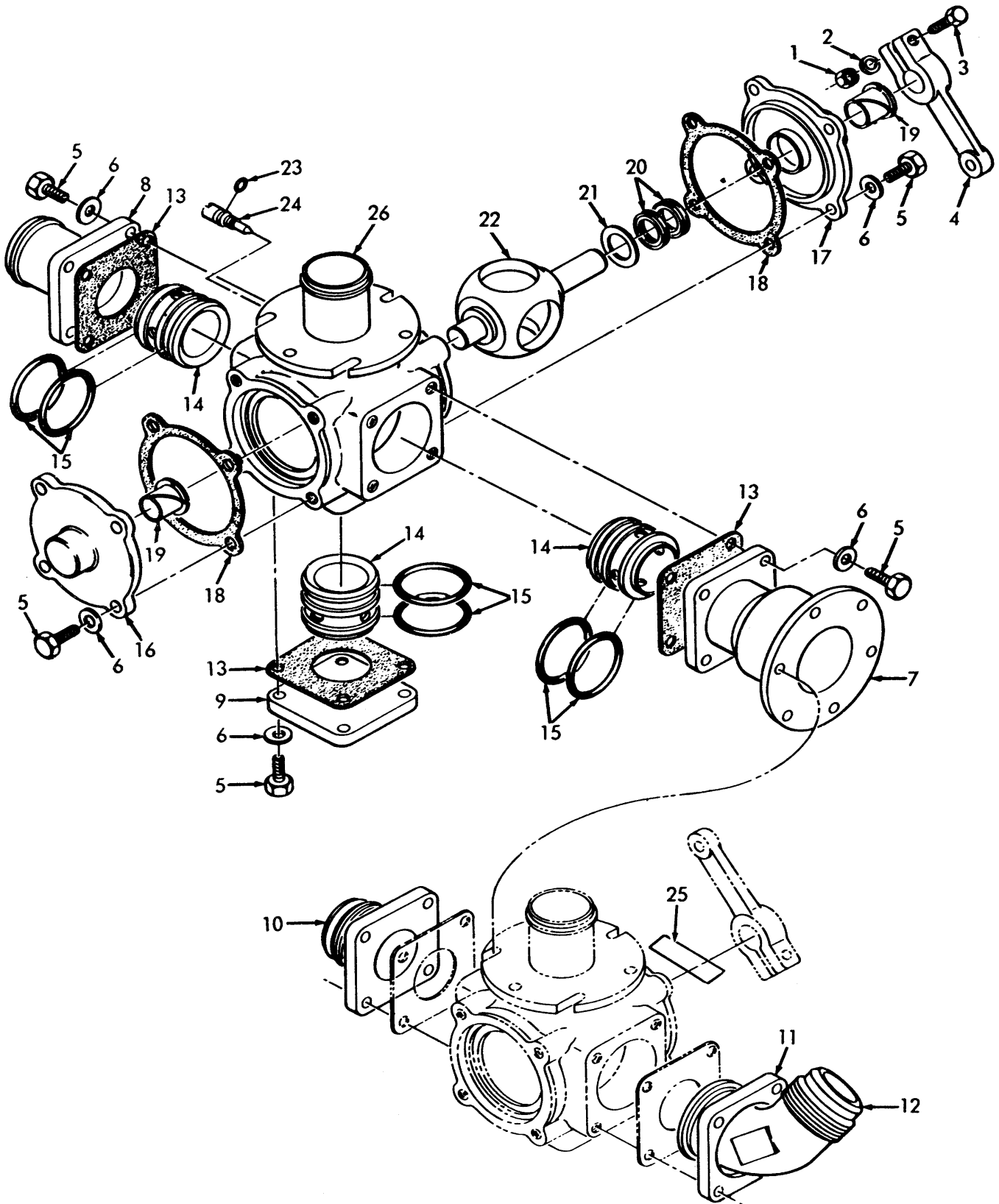
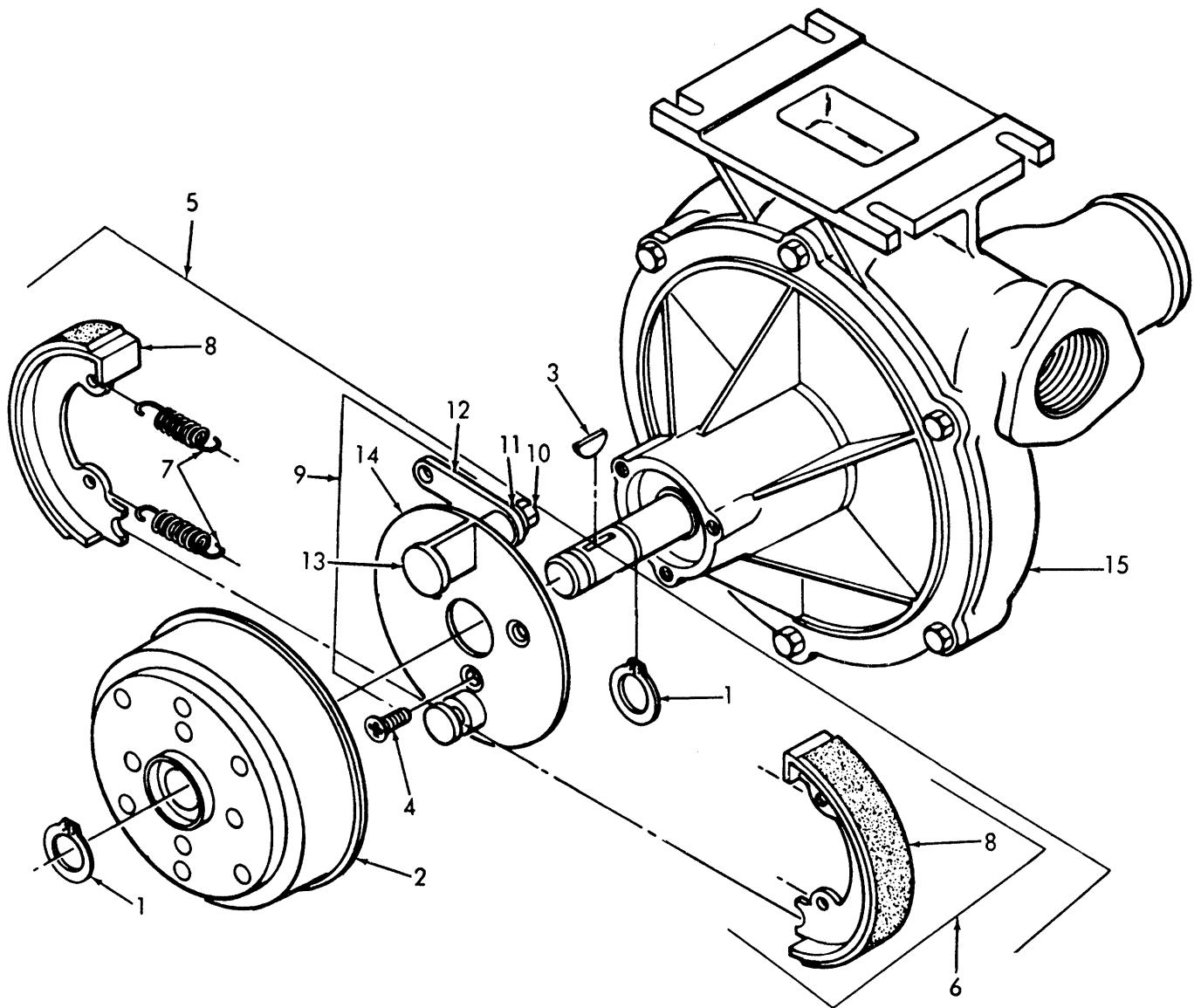

Figure 7. Sprayer Manual Control and Valve Assembly.

SECTION II

TM 5-3740-211-24P

(1) ILLUSTRATION		(2)	(3)	(4)	(5)	(6) DESCRIPTION	(7)	(8)
(a) FIG NO.	(b) ITEM NO.	SMR CODE	NATIONAL STOCK NUMBER	PART NUMBER	FSCM	USABLE ON CODE	U/M	QTY INC IN UNIT
7	1	XBOZZ		MS20365-1032	96906	NUT, PLAIN, HEXAGON LEVER	EA	2
7	2	PAOZZ	5310-00-167-0818	AN960-10	88044	WASHER, FLAT LEVER.....	EA	2
7	3	PAOZZ	5306-00-151-0781	AN3-13A	88044	BOLT, MACHINE LEVER.....	EA	2
7	4	XBOZZ		7208	22065	LEVER CONTROL AND BYPASS VALVE ASSEMBLIES.....	EA	2
7	5	PAOZZ	5305-00-068-0502	MS90725-6	96906	SCREW, CAP, HEXAGON READ FITTING MOUNTING.....	EA	36
7	6	XBOZZ		AN916-416	88044	WASHER, LOCK FITTING MOUNTING.....	EA	36
7	7	XBOZZ		7569	22065	FITTING.....	EA	1
7	8	XBOZZ		6538-1	22065	FITTING CONTROL VALVE.....	EA	1
7	9	XBOZZ		7517	22065	CAP, END CONTROL VALVE.....	EA	2
7	10	XBOZZ		7538	22065	FITTING BYPASS VALVE.....	EA	1
7	11	XBOZZ		6517	22065	FLANGE BYPASS VALVE.....	EA	1
7	12	XBOZZ		7542	22065	FITTING BYPASS VALVE.....	EA	1
7	13	KFOZZ		6527	22065	GASKET PART OF KIT P/N K7520-1.....	EA	5
7	14	KFOZZ		7516	22065	SEAT, VALVE PART OF KIT P/N K7520-1....	EA	6
7	15	KFOZZ		7513	22065	PACKING, PREFORMED PART OF KIT P/NK 7520-1.....	EA	12
7	16	XBOZZ		7514	22065	CAP, END BY-PASS VALVE.....	EA	2
7	17	XBOZZ		7515	22065	CAP SHAFT END.....	EA	2
7	18	KFOZZ		7307	22065	GASKET END CAP PART OF KIT P/NK 7520-1	EA	4
7	19	KFOZZ		7311	22065	BEARING, SHAFT PART OF KIT P/NK 7520-1	EA	4
7	20	KFOZZ		7210	22065	RING, QUAD PART OF KIT P/N K7520-1.....	EA	4
7	21	KFOZZ		7310	22065	WASHER, THRUST PART OF KIT P/NK7520-1	EA	2
7	22	XBOZZ		7512	22065	BALL, VALVE.....	EA	2
7	23	KFOZZ		622706	22065	PACKING, PREFORMED PART OF KIT P/NK 7520-1.....	EA	2
7	24	XBOZZ		7313	22065	SCREW, FLOW BY-PASS VALVE.....	EA	2
7	25	XBOZZ		30207	22065	PLATE, INSTRUCTION.....	EA	1
7	26	XBOZZ		7502-1	22065	BODY, VALVE.....	EA	2
7		PAOZZ	4820-00-494-2300	K7520-1	22065	PARTSKIT, VALVE VALVE ASSEMBLY.....	EA	1
7	14					GASKET.....	EA	2
7	13					GASKET.....	EA	5
7	14					SEAT, VALVE.....	EA	6
7	15					PACKING, PREFORMED.....	EA	12
7	18					GASKET.....	EA	4
7	19					BEARING, SHAFT.....	EA	4
7	20					RING, QUAD.....	EA	4
7	21					WASHER, THRUST.....	EA	2
7	23					PACKING, PREFORMED.....	EA	2



TS 3740-211-24P/8

Figure 8. Sprayer Pump and Brake Assembly.

SECTION II

TM 5-3740-211-24P

(1) ILLUSTRATION		(2)	(3)	(4)	(5)	(6) DESCRIPTION	(7)	(8)
(a) FIG NO.	(b) ITEM NO.	SMR CODE	NATIONAL STOCK NUMBER	PART NUMBER	FSCM	USABLE ON CODE	U/M	QTY INC IN UNIT
						GROUP 03 - SPRAYER PUMP AND BRAKE ASSEMBLY		
8	1	XBFZZ		5160-66	22065	RING, SNAP DRUM MOUNTING.....	EA	2
8	2	PAFZZ	3740-00-494-3839	6371	22065	DRUM AND FLANGE ASSEMBLY	EA	1
8	3	PAFZZ	5315-00-616-5521	MS35756-13	96906	KEY, WOODRUFF	EA	1
8	4	XBFZZ		1016-50	22065	SCREW, MACHINE	EA	3
8	5	XBFZZ		6370	22065	BRAKE ASSEMBLY SPRAYER	EA	1
8	6	XBFZZ		6370-1	22065	.BRAKE ASSEMBLY.....	EA	1
8	7	PAFZZ	5360-00-763-0862	6370-15	22065	..SPRING, HELICAL BRAKE SHOES.....	EA	2
8	8	PAFZZ	3740-00-494-3840	6370-13	22065	..SHOE, BRAKE	ST	1
8	9	XBFZZ		6370-3	22065	..BACKPLATE ASSEMBLY BRAKE.....	EA	1
8	10	XBFZZ		MS20364-524C	96906	...NUT, PLAIN, HEXAGON CAM MOUNTING	EA	1
8	11	XBFZZ		6370-19	22065	...WASHER, LOCK CAM MOUNTING.....	EA	1
8	12	XBFZZ		6370-21	22065	...LEVER BRAKE PLATE	EA	1
8	13	XBFZZ		6370-17	22065	...CAM BRAKE PLATE.....	EA	1
8	14	XBFZZ		6370-11	22065	...PLATE BRAKE BACK	EA	1
8	15	PAFZZ	3740-00-179-6713	6300T5	22065	PUMP ASSEMBLY	EA	1
					21			

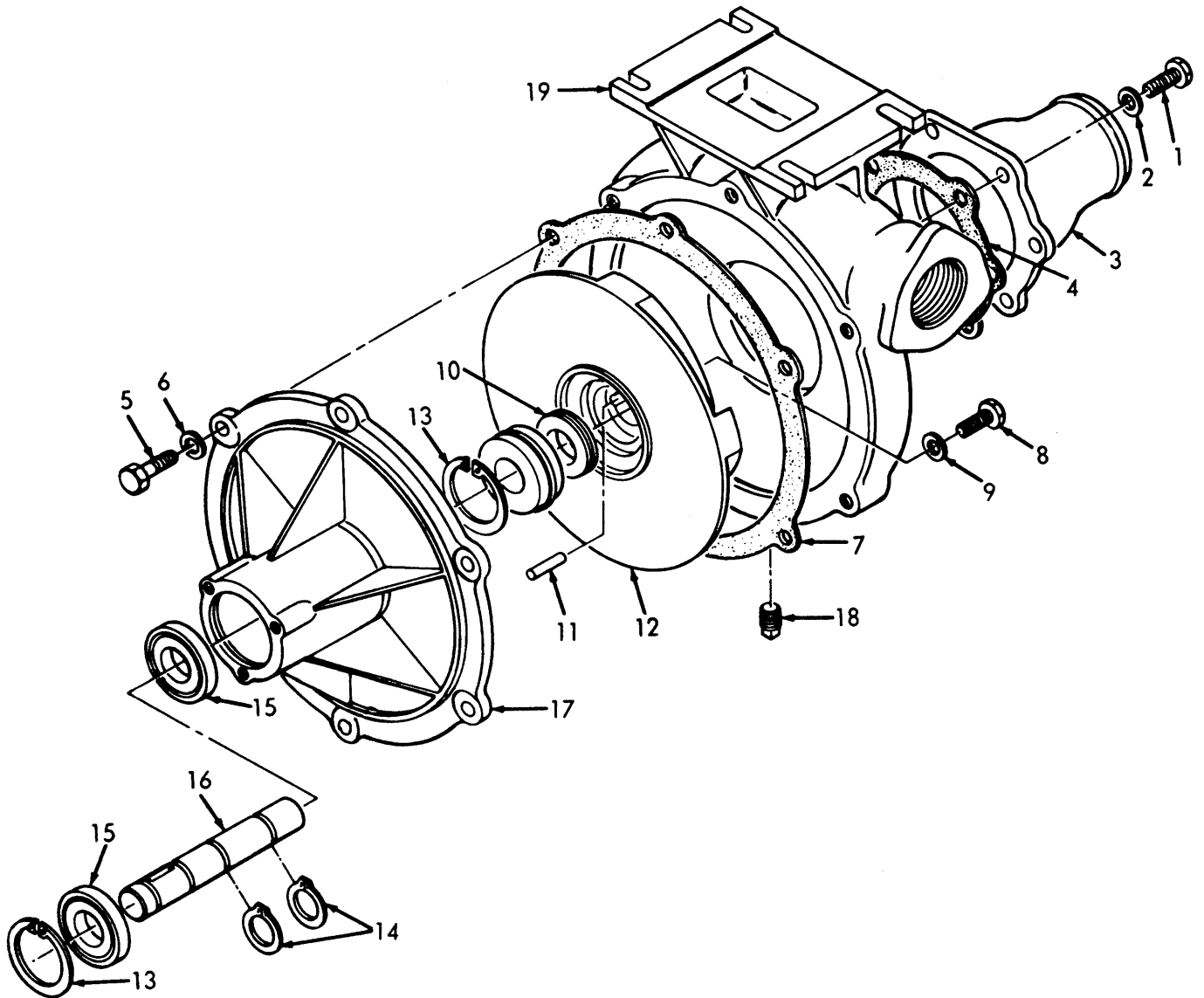

TS 3740-211-24P/9

Figure 9. Sprayer Pump Assembly.

SECTION II

TM 5-3740-211-24P

(1) ILLUSTRATION		(2)	(3)	(4)	(5)	(6)	(7)	(8)
(a) FIG NO.	(b) ITEM NO.	SMR CODE	NATIONAL STOCK NUMBER	PART NUMBER	FSCM	DESCRIPTION USABLE ON CODE	U/M	QTY INC IN UNIT
						GROUP 04 - SPRAYER PUMP ASSEMBLY		
9	1	PAOZZ	5305-00-068-0501	MS90725-5	96906	SCREW, CAP, HEXAGON INLET MOUNTING	EA	6
9	2	PAOZZ	5310-00-141-1795	AN960-416	88044	WASHER, FLAT INLET MOUNTING.....	EA	6
9	3	XBOZZ		6639	22065	INLET, CASE SPRAYER PUMP.....	EA	1
9	4	PAOZZ	3740-00-179-6711	6642	22065	GASKET INLET	EA	1
9	5	PAFZZ	5306-00-225-8497	MS90725-32	96906	SCREW, CAP, HEXAGON HEAD PUMP BODY MOUNTING	EA	6
9	6	PAFZZ	5310-00-167-0820	AN960-516	88044	WASHER, FLAT PUMP BODY MOUNTING..	EA	6
9	7	PAFZZ	3740-00-179-6715	6306	22065	GASKET CASE	EA	1
9	8	XBFZZ		AN4C6ALL	88044	BOLT, MACHINE IMPELLER MTG	EA	1
9	9	PAFZZ	5310-00-531-9515	AN960C416	88044	WASHER, FLAT IMPELLER MOUNTING	EA	1
9	10	PAFZZ	5330-00-179-6248	6308T	22065	SEAL ASSEMBLY IMPELLER.....	EA	1
9	11	XBFZZ		6609	22065	PIN, STRAIGHT IMPELLER.....	EA	1
9	12	PAFZZ	3740-00-179-6716	6302	22065	IMPELLER PUMP	EA	1
9	13	PAFZZ	5365-00-804-9746	MS16625-156	96906	RING, SNAP SEAL MOUNTING	EA	2
9	14	XBFZZ		5160-66	22065	RING, SNAP IMPELLER SHAFT.....	EA	2
9	15	PAFZZ	3110-00-156-8384	6203	22065	BEARING, PLAIN SPRAYER PUMP	EA	2
9	16	PAFZZ	3740-00-179-6719	6305	22065	SHAFT, IMPELLER SPRAYER PUMP	EA	1
9	17	XBFZZ	3740-00-179-6717	6301	22065	BODY, PUMP SPRAYER.....	EA	1
9	18	XBOZZ		1604-34C	79555	PLUG, NYLON SPRAYER PUMP BODY.....	EA	1
9	19	XBFZZ		6303-3	22065	CASE, PUMP SPRAYER	EA	1
					23			

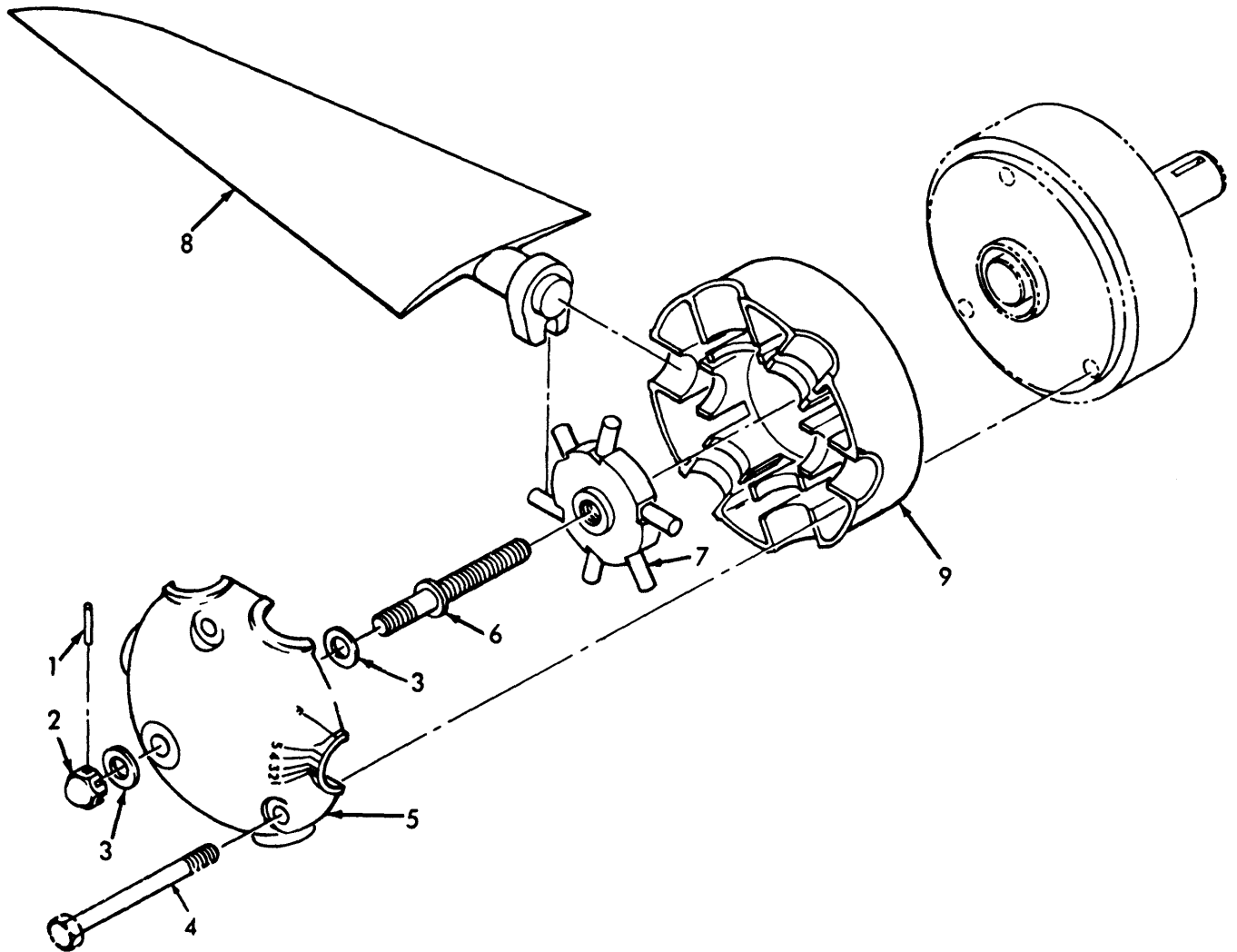

TS 3740-211-24P/10

Figure 10. Sprayer Synchronomatic Windmill Assembly.

SECTION II

TM 5-3740-211-24P

(1) ILLUSTRATION		(2)	(3)	(4)	(5)	(6)	(7)	(8)
(a) FIG NO.	(b) ITEM NO.	SMR CODE	NATIONAL STOCK NUMBER	PART NUMBER	FSCM	DESCRIPTION USABLE ON CODE	U/M	QTY INC IN UNIT
						GROUP 05 - SPRAYER SYNCHROMATIC WINDMILL ASSEMBLY		
10	1	XBOZZ		6673	22065	PIN, ROLL NUT LOCKING	EA	1
10	2	PAOZZ	5310-00-797-3615	6672	22065	HUB CAP MOUNTING.....	EA	1
10	3	PAOZZ	5310-00-187-2395	AN960PD616L	88044	WASHER, FLAT HUB CAP MOUNTING	EA	2
10	4	XBOZZ		6674	22065	BOLT, MACHINE HUB CAP MOUNTING	EA	3
10	5	PAOZZ	3740-00-179-6706	6648	22065	CAP, HUB WINDMILL	EA	1
10	6	XBOZZ		6653	22065	SCREW ADJUSTING	EA	1
10	7	PAOZZ	3740-00-179-6707	6652	22065	ACTUATOR WINDMILL.....	EA	1
10	8	XBOZZ		6649-33	22065	BLADE WINDMILL	EA	6
10	9	PAOZZ	3740-00-179-6705	6647	22065	HUB, BASE WINDMILL	EA	1
					25			

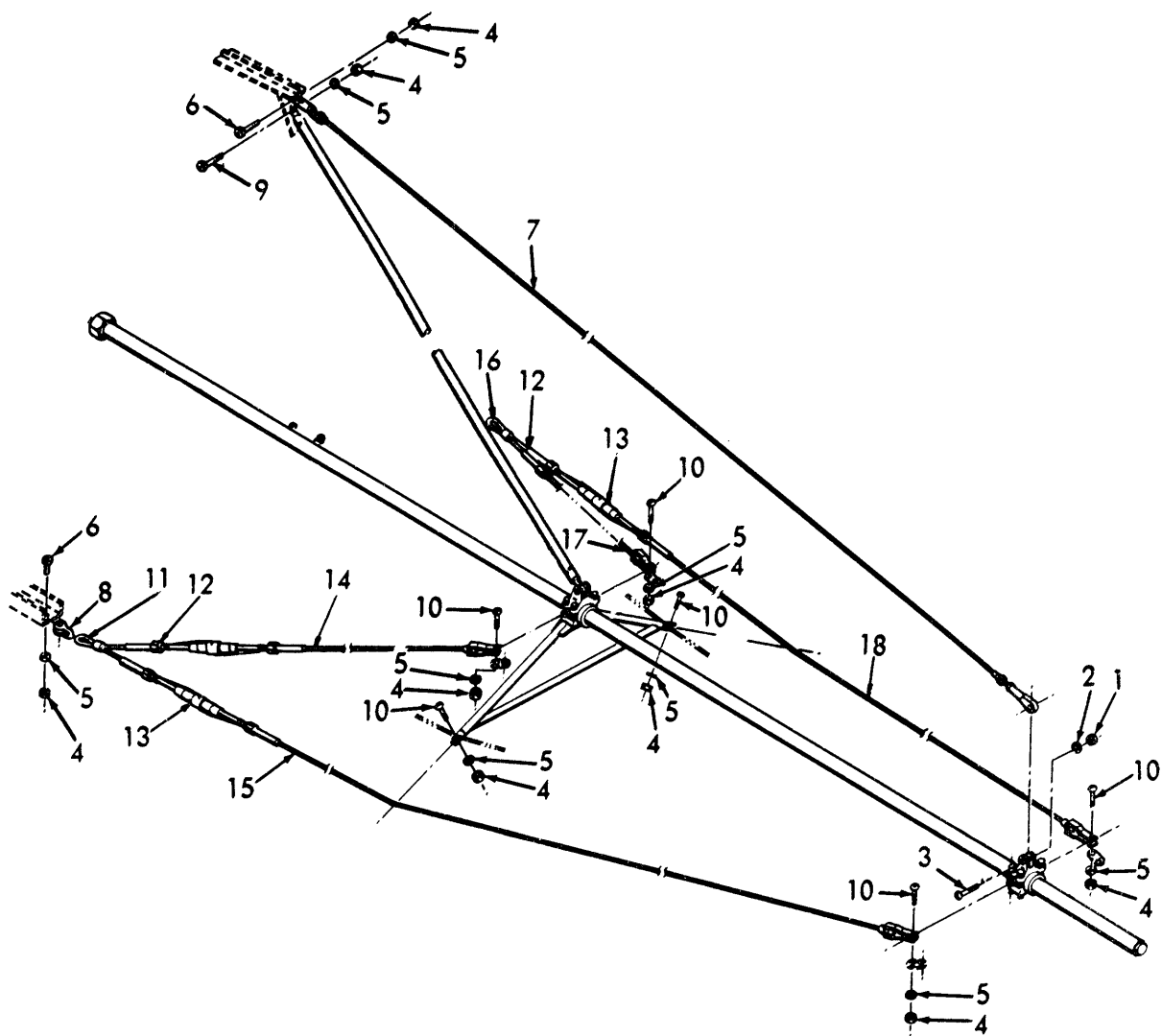

TS 3740-211-24P/11

Figure 11. Sprayer Boom Assembly.

(1) ILLUSTRATION		(2)	(3)	(4)	(5)	(6) DESCRIPTION	(7)	(8)
(a) FIG NO.	(b) ITEM NO.	SMR CODE	NATIONAL STOCK NUMBER	PART NUMBER	FSCM	USABLE ON CODE	U/M	QTY INC IN UNIT
						GROUP 06 - SPRAYER BOON ASSEMBLY		
11	1	PAOZZ	5310-00-889-2589	KS21044C4	96906	NUT, SEIF-LOCKING	EA	4
11	2	PAOZZ	5310-00-582-S677	NS15795-810	96906	WASHER, FLAT	EA	4
11	3	XBOZZ		AN24-18A	88044	BOLT, MACHINE CEVIS.....	EA	4
11	4	PAOZZ	5310-00-208-92S5	MS21044C3	96906	NUT, SELF-LOCKING	EA	34
11	5	PAOZZ	5310-00-619-1148	NS15795-808	96906	WASHER, FLAT	EA	34
11	6	PAOZZ	5306-00-156-2327	AN3C6A	88044	BOLT, MACHINE CABLE MOUNTING	EA	6
11	7	PAOZZ	3740-00-179-6733	3085-1	22065	CABLE BOOM SUPPORT	EA	2
11	8	XBOZZ		3085-5	22065	SHACKLE, WIRE ROPE.....	EA	4
11	9	PAOZZ	5306-00-156-2329	AN3C10A	88044	BOLT, MACHINE STRUT MOUNTING.....	EA	6
11	10	XBOZZ		AN23-14A	88044	BOLT, MACHINE CLEVIS.....	EA	6
11	11	XBOZZ		30293	22065	CABLE FRONT BOOM	EA	2
11	12	XDOZZ		30209	22065	FORK, CABLE BOOM	EA	4
11	13	PAOZZ	5340-00-067-9880	MS21251BSL	96906	TURNBUCLIE.....	EA	8
11	14	XBOZZ		30208-2	22065	CABLE BOOM.....	EA	2
11	15	XBOZZ		30208-4	22065	CABL BOOM	EA	2
11	16	XBOZZ		30294	22065	CABL REAR BOOM.....	EA	2
11	17	XBOZZ		30208-1	22065	CABLE BOOM.....	EA	2
11	18	XBOZZ		30208-3	22065	CABLE BOOM.....	EA	2
					27			

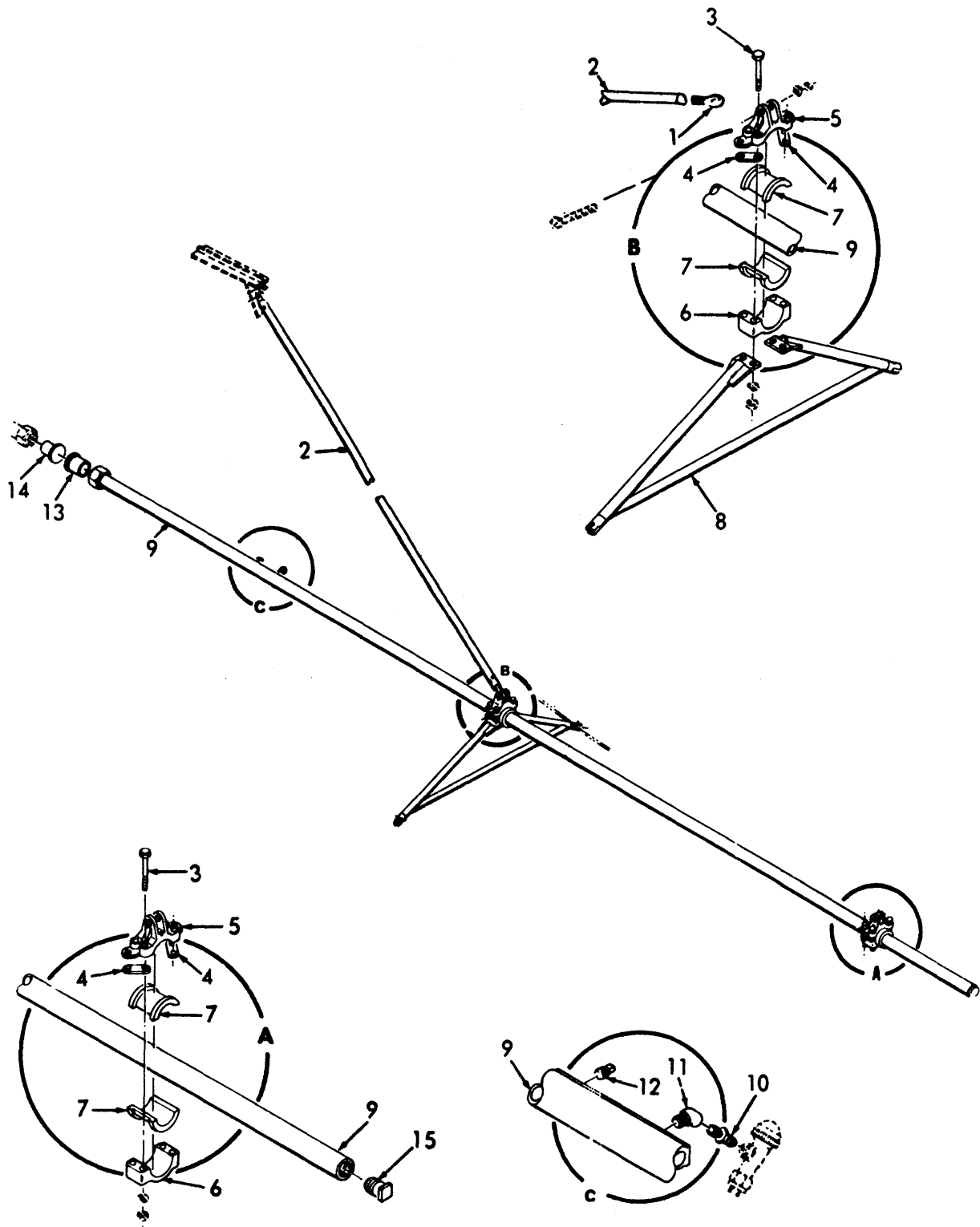

TS 3740-211-24P/12

Figure 12. Boom Assembly.

SECTION II

TM 5-3740-211-24P

(1) ILLUSTRATION		(2)	(3)	(4)	(5)	(6)	(7)	(8)
(a) FIG NO.	(b) ITEM NO.	SMR CODE	NATIONAL STOCK NUMBER	PART NUMBER	FSCM	DESCRIPTION USABLE ON CODE	U/M	QTY INC IN UNIT
12	1	XBOZZ		MD46-16	73134	ROD END BOOM STRUT	EA	2
12	2	XBOZZ		30299	22065	STRUT BOOM SUPPORT	EA	2
12	3	XBOZZ		AN3-22A	88044	BOLT, MACHINE	EA	16
12	4	PAOZZ	3040-00-306-7423	13216E5407	97403	LINK, CLAMP BOOM.....	EA	8
12	5	XBOZZ		30361	22065	CLAMP, TUBE BOOM	EA	4
12	6	XBOZZ		30362	22065	CLAMP, TUBE BOTTOM	EA	4
12	7	XBOZZ	3740-00-179-6726	3032	22065	RING, HALF CLAMP.....	EA	8
12	8	XBOZZ		30292	22065	BRACE BOOM	EA	2
12	9	XBOZZ		30296	22065	TUBE BOOM	EA	2
12	10	PAOZZ	4730-00-278-3721	SAEJ530FIG1	81343	NIPPLE, HEXAGON BOOM.....	EA	60
12	11	PAOZZ	4730-00-231-3905	SAEJ530FIG14	81343	ELBOW, STREET BOOM.....	EA	60
12	12	PAOZZ	4730-00-011-3175	SAEJ531FIG1A	81343	PLUG, PIPE BOOM.....	EA	60
12	13	PAOZZ	4730-00-221-2115	AN929-24D	88044	CAP.....	EA	2
12	14	XBOZZ		AN806-24D	88044	PLUG, FLARED TUBE BOOM.....	EA	2
12	15	XBOZZ		8400-34	82247	PLUG, HEXAGON BOOM.....	EA	2
					29			

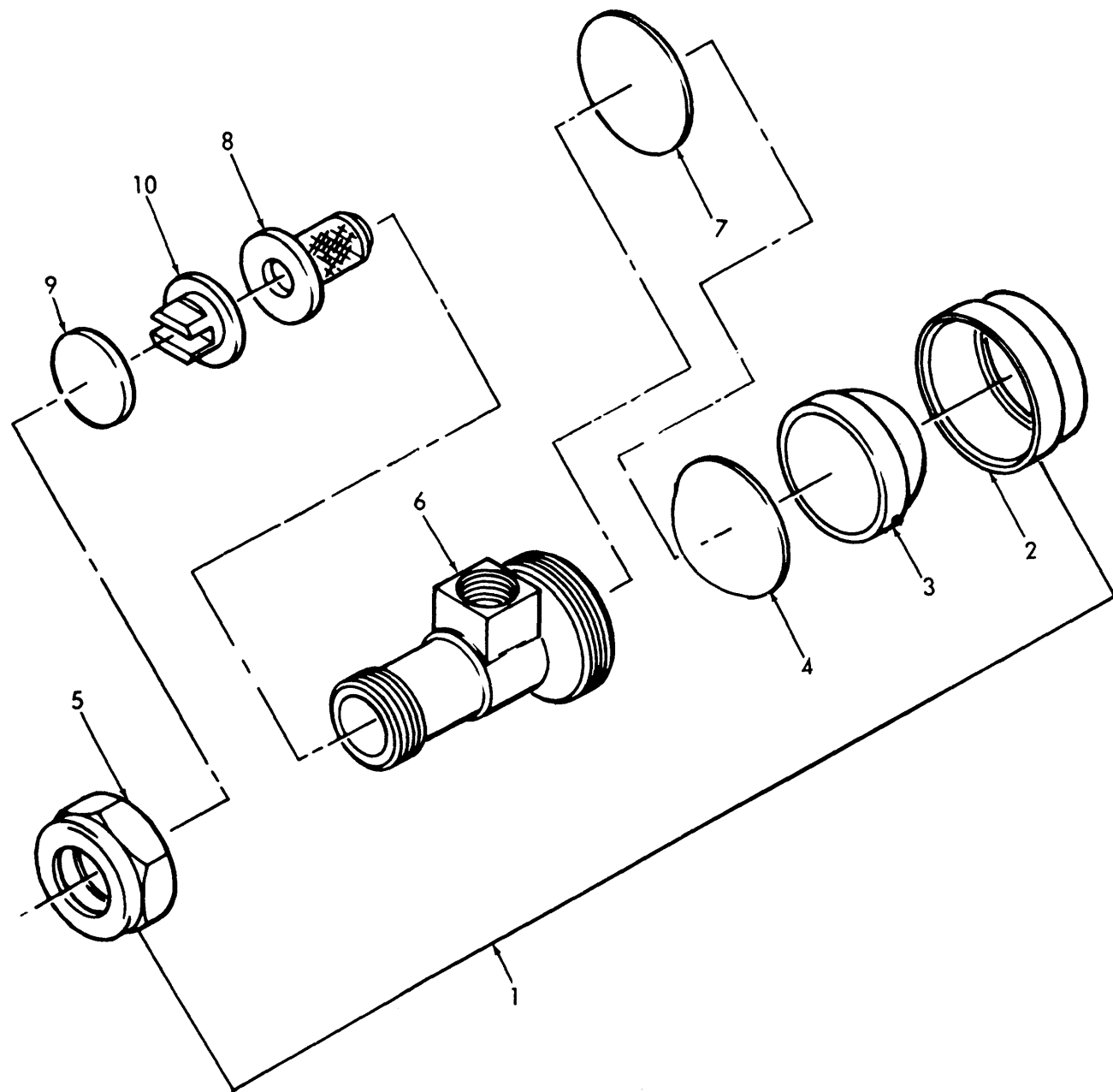

TS 3740-211-24P/13

Figure 13. Sprayer Nozzle Assembly.

SECTION II

TM 5-3740-211-24P

(1) ILLUSTRATION		(2)	(3)	(4)	(5)	(6) DESCRIPTION	(7)	(8)
(a) FIG NO.	(b) ITEM NO.	SMR CODE	NATIONAL STOCK NUMBER	PART NUMBER	FSCM	USABLE ON CODE	U/M	QTY INC IN UNIT
						GROUP 07 - SPRAYER NOZZLE ASSEMBLY		
13	1	XBOZZ		30399-1	22065	NOZZLE ASSEMBLY . SPRAY, INSECTICIDE	EA	60
13	2	XBOZZ		4624ALEF	82247	RETAINER, CAP NOZZLE	EA	60
13	3	XBOZZ		9758ASBALEF	82247	.CAP ASSEMBLY, END NOZZLE.....	EA	60
13	4	XBOZZ		4620V1	82247	.DIAPHRAGM, NOZZLE SPRAYER	EA	60
13	5	XBOZZ	3740-00-283-9346	1325ALEF	82247	.CAP, STRAINER END NOZZLE.....	EA	60
13	6	XBOZZ		4618ALEF	82247	.BODY ASSEMBLY SPRAYER	EA	60
13	7	XBOZZ		6227TEF	82247	DIAPHRAGM, SECONDARY NOZZLE.....	EA	60
13	8	XBOZZ	5053AL50MESH	82247		STRAINER ASSEMBLY SPRAYER.....	EA	60
13	8	XBOZZ	5053AL100MESH	82247		STRAINER ASSEMBLY SPRAYER.....	EA	60
13	9	XBOZZ		3942AL	82247	TIP, SPRAY.....	EA	60
13	10	XBOZZ		8001SS	82247	TIP, SPRAY.....	EA	60
13	10	PAOZZ	3740-00-403-5244	80015SS	82247	TIP, SPRAY, FLAT INSECTICIDE.....	EA	60
13	10	PAOZZ	3740-00-403-5266	8002SS	82247	TIP, SPRAYER, INSECTICIDE	EA	60
13	10	PAOZZ	3740-00-403-5267	8003SS	82247	TIP, SPRAYER, INSECTICIDE	EA	60
13	10	PAOZZ	3740-00-403-5269	8004SS	82247	TIP, SPRAYER, INSECTICIDE	EA	60
					31			

SECTION II

TM 5-3740-211-24P

(1) ILLUSTRATION		(2)	(3)	(4)	(5)	(6)	(7)	(8)
(a) FIG NO.	(b) ITEM NO.	SMR CODE	NATIONAL STOCK NUMBER	PART NUMBER	FSCM	DESCRIPTION USABLE ON CODE	U/M	QTY INC IN UNIT
						GROUP 08 - SPRAYER SKID AND SHIPPING PARTS		
14		XBOZZ		30340	22065	SKID, SPRAYER	IEA	1
14	1	XBOZZ		SIZE3GFP	81348	CHEST, FIELD, EMPTY	EA	1
14	2	XBOZZ		30332	22065	STRAP, RETAINING CHEST	EA	
14	3	PAOZZ	5310-00-982-4971	MS21046C6	96906	NUT, SELF-LOCKING	EA	12
14	4	XBOZZ		30214	22065	LOOP, STRAP CHEST RETAINING	EA	2
14	5	PAOZZ	5310-00-828-8189	MS35425-41	96906	NUT, PLAIN, WING	EA	2
14	6	PAOZZ	5310-00-167-0767	AN970-5	88044	WASHER, FLAT	EA	2
14	7	PAOZZ	1670-00-179-6252	WB661-1-25N	95957	STRAP, RETAINING	EA	2
14	8	PAOZZ	1670-00-179-6251	WB661-1-52N	95957	STRAP, RETAINING TANK	EA	2
14	9	PAOZZ	5340-00-008-2053	MS17990C632	96906	PIN, QUICK RELEASE FRAME MOUNTING.	EA	4
14	10	XBOZZ		130341	22065	BASE, SKID SPRAYER	EA	1
14	11	XBOZZ		3095-67	22065	NUT, LOCKING TANK MOUNTING	EA	4
14	12	PAOZZ	5305-00-988-7794	MS24671-30	96906	SCREW, CAP, SOCKET HEAD	EA	4
14	13	XBOZZ		3095-69	22065	BOLT, LOCKING	EA	4
14	14	XBOZZ		AN504C1032-10	88044	SCREW, TAPPING	EA	2
14	15	XBOZZ		3095-83	22065	PLATE STRAP	EA	1
14	16	PAOZZ	5340-00-004-7107	MS17987C411	96906	PIN, QUICK RELEASE FRAME	EA	2
14	17	PAOZZ	5310-00-982-4999	MS21044C04	96906	NUT, SELF-LOCKING	EA	1
14	18	PAOZZ	5305-00-054-5654	MS51957-20	96906	SCREW, MACHINE	EA	1
14	19	PAOZZ	4010-00-837-3649	432-1153-000	13499	ROPE, WIRE	EA	1
14	20	XBOZZ		316X035X50	22065	TUBING, COPPER SEAMLESS, 3/16 OD X 0.035 WALL X 0.50 LG	EA	1
14	21	PAOZZ	5310-00-889-2589	MS21044C4	96906	NUT, SELF-LOCKING	EA	6
14	22	PAOZZ	5305-00-760-6889	MS35308-320	96906	SCREW, CAP, HEXAGON HEAD	EA	6
14	23	XBOZZ		3095-21	22065	RETAINER, PAD SKID FRAME	EA	4
14	24	PAOZZ	5310-00-889-2606	MS35425-42	96906	NUT, PLAIN, WING	EA	6
14	25	XBOZZ		3095-35	22065	PAD, SKID	EA	4
14	26	XBOZZ		3095-23	22065	RETAINER, PAD SKID FRAME	EA	2
14	27	XBOZZ		3095-37	22065	PAD, SKID	EA	2
14	28	XBOZZ		30349	22065	FRAME, SKID SPRAYER	EA	1
					33			

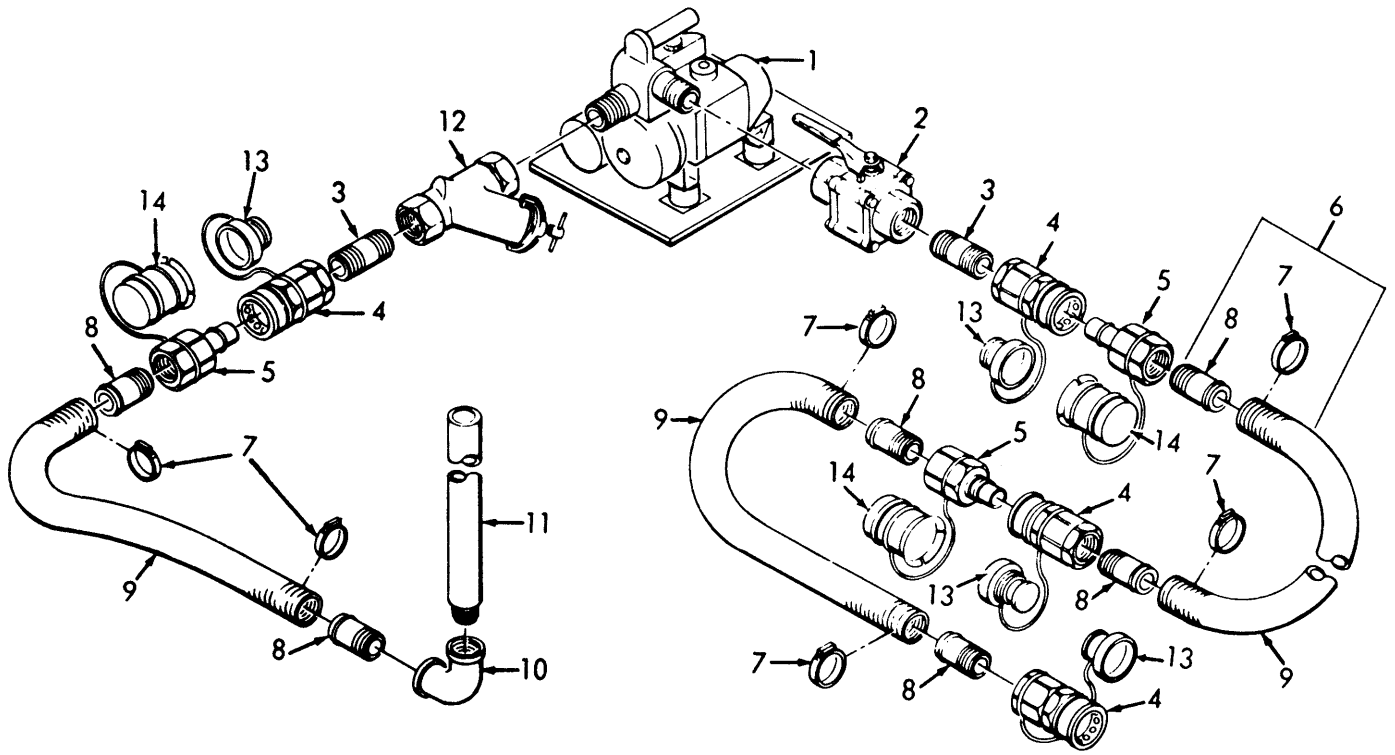

TS 3740-211-24P/15

Figure 15. Liquid Loading System.

SECTION II

TM 5-3740-211-24P

(1) ILLUSTRATION		(2)	(3)	(4)	(5)	(6)	(7)	(8)
(a) FIG NO.	(b) ITEM NO.	SMR CODE	NATIONAL STOCK NUMBER	PART NUMBER	FSCM	DESCRIPTION USABLE ON CODE	U/M	QTY INC IN UNIT
						GROUP 09 - LIQUID LOADING SYSTEM		
15		AOZZ		30320	22065	LOADING SYSTEM SPRAYER.....	EA	1
15	1	XBOZF		XLS1-12-3	29201	.PUMP, LOADING SYSTEM	EA	1
15	2	XBOZZ		1-12-436TSE	98991	.VALVE, BALL	EA	1
15	3	XBOZZ		30330	22065	.NIPPLE, PIPE 1.9 DIA X 3.0 LG	EA	2
15	4	PAOZZ	4730-00-764-7845	AVKC24-24F	78357	.COUPLER, VALVE	EA	4
15	5	PAOZZ	4730-00-319-4895	AVKN24-24F	78357	.COUPLER, VALVE	EA	3
15	6	XBOZZ		30327	22065	.HOSE ASSMBLY	EA	3
15	7	XBOZZ		MS35842-13	70318	..CLAMP, HOSE	EA	6
15	8	PAOZZ	4730-00-881-2220	MS24522-34	96906	..ADAPTER, PIPE TO HOSE	EA	6
15	9	PAOZZ	4720-00-543-8883	4218-24	98441	..HOSE, FLEXIBLE	EA	3
15	10	XBOZZ		30317	22065	.ELBOW, PIPE	EA	1
15	11	XBOZZ		3083-13	22065	.PIPE, SUCTION	EA	1
15	12	XBOZZ		4i64P30G	22065	.STRAINER	EA	1
15	13	XBOZZ		ADPK24	78357	.PLUG, DUST	EA	3
15	14	XBOZZ		ADCK24	78357	.CAP, DUST	EA	4
					35			

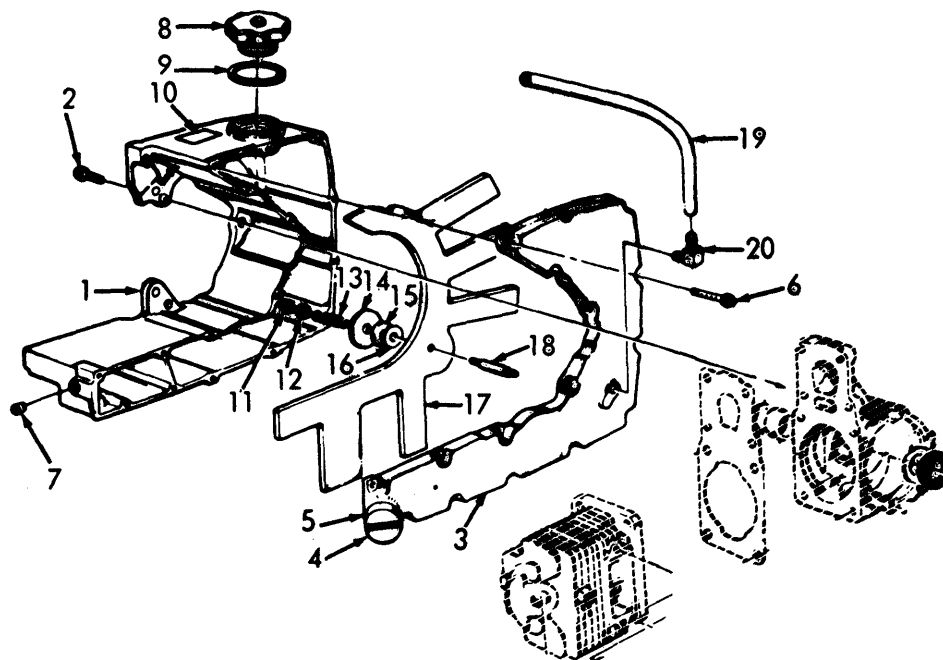

TS 3740-211-24P/16

Figure 16. Fuel and Oil Tank.

SECTION II

TM 5-3740-211-24P

(1) ILLUSTRATION		(2)	(3)	(4)	(5)	(6) DESCRIPTION	(7)	(8)
(a) FIG NO.	(b) ITEM NO.	SMR CODE	NATIONAL STOCK NUMBER	PART NUMBER	FSCM	USABLE ON CODE	U/M	QTY INC IN UNIT
						GROUP 10 - LIQUID LOADING SYSTEM PUMP ENGINE		
16	1	XBFZZ		58734-2	29201	TANK, FUEL AND OIL	EA	1
16	2	XBFZZ		63407	29201	SCREW, SHOULDER.....	EA	3
16	3	XBFZZ		A63271	29201	COVER, FUEL TANK.....	EA	1
16	4	XBOZZ		A56580-1	29201	.CAP, SLOTTED.....	EA	1
16	5	XBOZZ		56607	29201	.GASKET CAP.....	EA	1
16	6	XBFZZ		80513	29201	SCREW, MACHINE.....	EA	16
16	7	XBFZZ		59571	29201	PLUG, PIPE	EA	1
16	8	PAOZZ	2910-00-177-7767	A64140-1	29201	CAP, FUEL.....	EA	1
16	9	XBOZZ		65358	29201	GASKET FUEL CAP	EA	1
16	10	XBOZZ		A64510-2	29201	PLATE, INSTRUCTION	EA	1
16	11	XBFZZ		81109	29201	NUT, LOCK	EA	1
16	12	XBFZZ		84003-1	29201	WASHER, LAT	EA	1
16	13	XBFZZ		58867	29201	SPRING, COMPRESSION.....	EA	1
16	14	XBFZZ		58866	29201	WASHER, WICK	EA	1
16	15	XBFZZ		59457	29201	WASHER, FELT	EA	1
16	16	XBFZZ		58865	29201	GASKET.....	EA	1
16	17	XBFZZ	9390-00-489-9507	58862	29201	WICK, FUEL PICK-UP.....	EA	1
16	18	XBFZZ		58519	29201	STUD, WICK	EA	1
16	19	PAOZZ	4720-00-177-7766	59644-1	29201	LINE, FUEL, FLEXIBLE	EA	1
16	20	XBFZZ		59642	29201	ELBOW FUEL LINE.....	EA	1
					37			

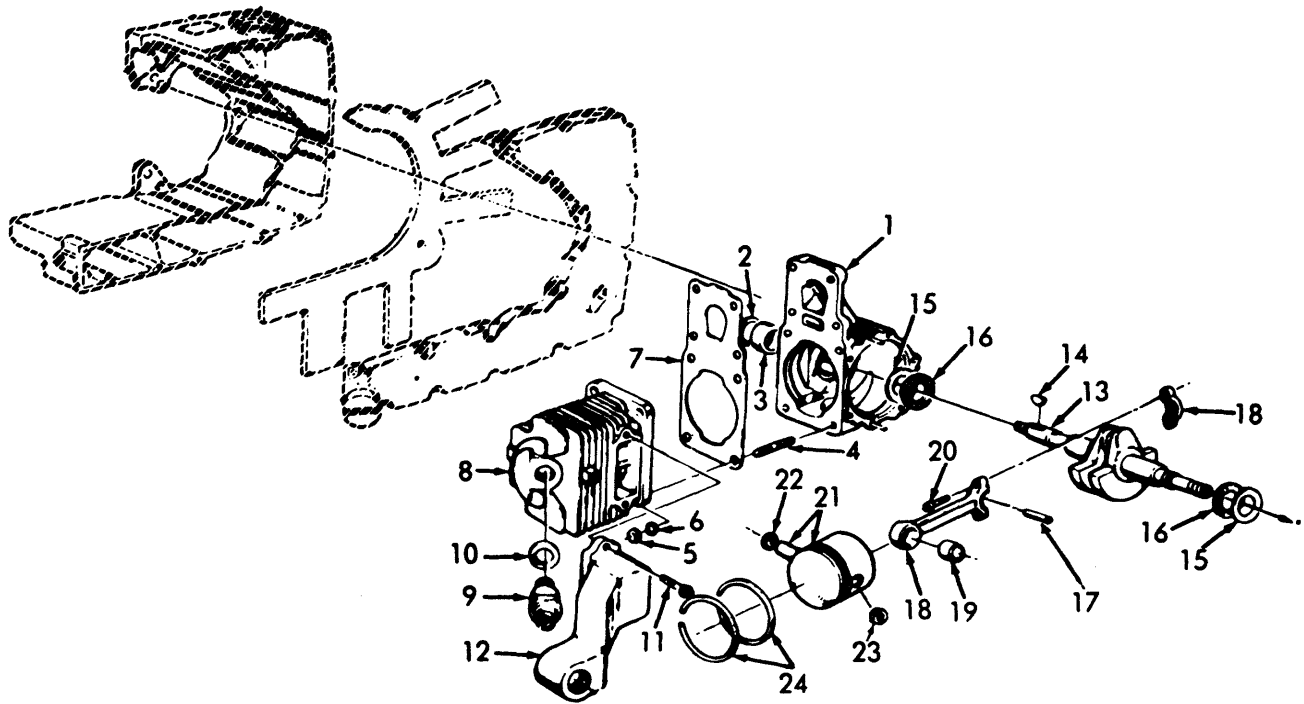

TS 3740-211-24P/17

Figure 17. Liquid Loading System.

SECTION II

TM 5-3740-211-24P

(1) ILLUSTRATION		(2)	(3)	(4)	(5)	(6)	(7)	(8)
(a) FIG NO.	(b) ITEM NO.	SMR CODE	NATIONAL STOCK NUMBER	PART NUMBER	FSCM	DESCRIPTION USABLE ON CODE	U/M	QTY INC IN UNIT
17	1	XBFZZ		A58799D	29201	CRANKCASE	EA	1
17	2	PAFZZ	5330-00-852-5034	58688A	29201	.SEAL	EA	1
17	3	PAFZZ	3110-00-227-4796	58956	29201	.BEARING	EA	1
17	4	XBFZZ		55871	29201	.STUD, PLAIN	EA	4
17	5	PAFZZ	5310-00-768-0319	MS51968-2	96906	NUT, PLAIN, HEXAGON.....	EA	4
17	6	XBFZZ		83009	29201	WASHER, LOCK	EA	4
17	7	PAFZZ	5330-00-983-6329	58513	29201	GASKET CRANKCASE	EA	1
17	8	XBFZZ		58706-4	29201	CYLINDER HEAD	EA	1
17	9	PAOZZ	2920-00-294-3788	54576S	29201	SPARK PLUG W/GASKET	EA	1
17	10	XAOZZ		25038	29201	.GASKET	EA	1
17	11	XBFZZ		80867	29201	SCREW, CAP, HEXAGON HEAD	EA	2
17	12	XBFZZ		59548-2	29201	MANIFOLD	EA	1
17	13	XBFZZ		63497-1	29201	CRANKSHAFT.....	EA	1
17	14	XBFZZ		75078	29201	KEY, WOODRUFF CRANKSHAFT	EA	1
17	15	PAFZZ	3110-00-926-4584	58725	29201	RACE THRUST BEARING	EA	2
17	16	PAFZZ	3110-00-629-4112	58726	29201	BEARING, NEEDLE.....	EA	2
17	17	PAFZZ	2805-00-837-1388	A63496	29201	ROLLER SET	EA	1
17	18	PAFZZ	2805-00-978-7293	A63477	29201	CONNECTING ROD	EA	1
17	19	XAFZZ		58724	29201	.BEARING	EA	1
17	20	XAFZZ		80889	29201	.SCREW, CAP, SOCKET HEAD CONNECTING ROD CAP	EA	2
17	21	PAFZZ	2805-00-978-7294	A58903C	29201	PISTON/PIN ASSEMBLY.....	EA	1
17	22	XAFZZ		75120	29201	.RING, RETAINING PISTON PIN.....	EA	1
17	23	XAFZZ		64813	29201	.RING, RETAINING PISTON PIN.....	EA	1
17	24	XAFZZ		58877	29201	.RING, PISTON	EA	2
					39			

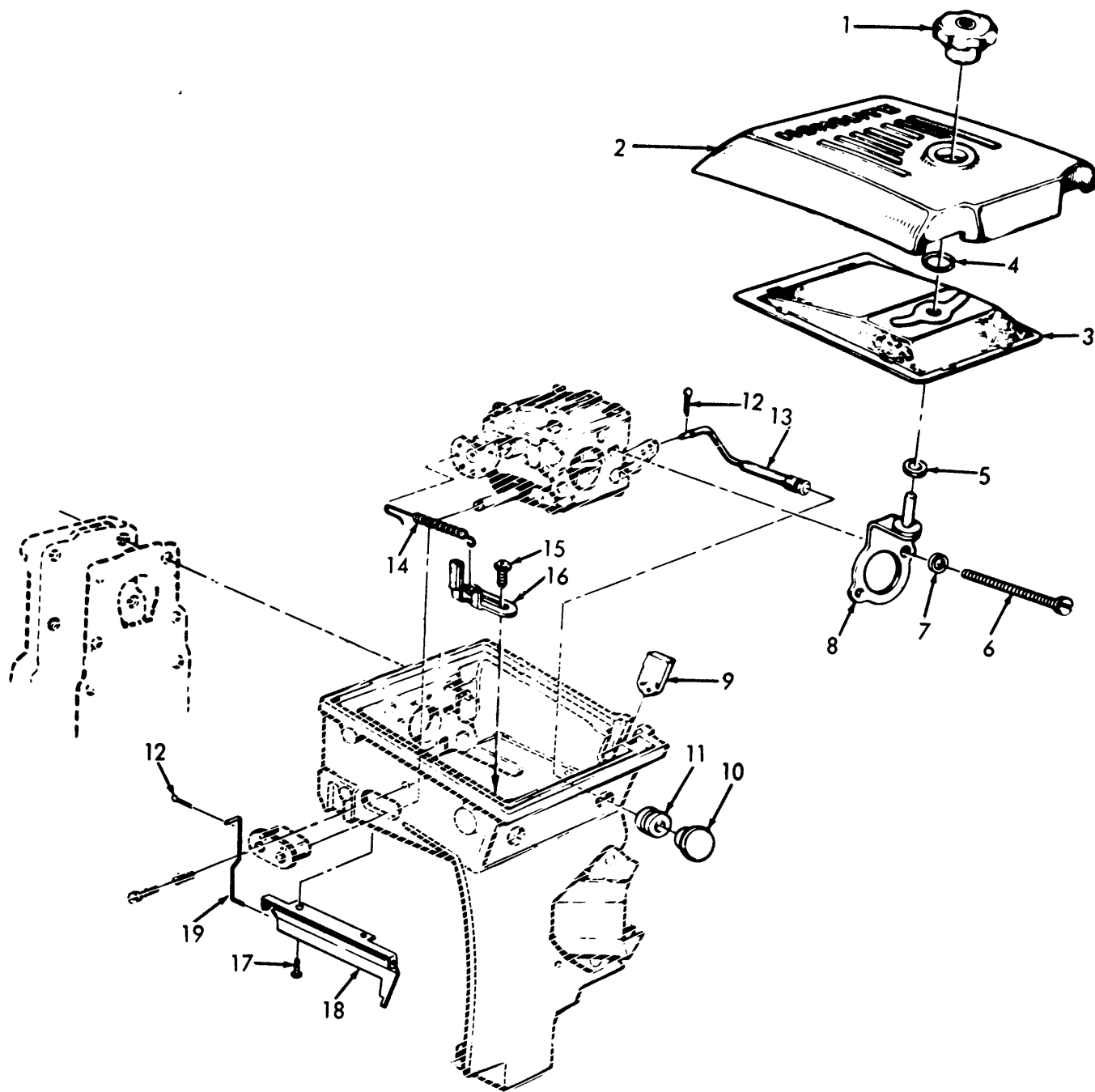

TS 3740-211-24P/18

Figure 18. Liquid Loading System Engine Carburetor Chamber

SECTION II

TM 5-3740-211-24P

(1) ILLUSTRATION		(2)	(3)	(4)	(5)	(6)	(7)	(8)
(a) FIG NO.	(b) ITEM NO.	SMR CODE	NATIONAL STOCK NUMBER	PART NUMBER	FSCM	DESCRIPTION USABLE ON CODE	U/M	QTY INC IN UNIT
						GROUP 11 - LIQUID LOADING SYSTEM ENGINE CARBURETOR CHAMBER		
18	1	XBOZZ		A58882	29201	NUT COVER	EA	1
18	2	XBOZZ		58773-5	29201	COVER	EA	1
18	3	PAOZZ	2940-00-982-9397	63589	29201	ELEMENT, FILTER.....	EA	1
18	4	XBOZZ		58319A	29201	RING, RETAINING	EA	1
18	5	PAOZZ	5330-00-840-4425	58392-1	29201	GASKET.....	EA	1
18	6	XBFZZ		80481	29201	SCREW, MACHINE BRACKET MOUNTING .	EA	2
18	7	XBFZZ		83046	29201	WASHER, LOCK BRACKET MOUNTING	EA	2
18	8	XBFZZ		A58818A	29201	BRACKET COVER	EA	1
18	9	XBOZZ		59329	29201	PLUG, FELT	EA	1
18	10	XBOZZ		57289-1	29201	BUTTON CHOKE ROD.....	EA	1
18	11	XBOZZ		58362	29201	GROMMET CHOKE ROD.....	EA	1
18	12	XBOZZ		86324	29201	PIN, COTTER CHOKE ROD.....	EA	2
18	13	XBFZZ		A58826	29201	ROD, CHOKE CARBURETOR.....	EA	1
18	14	XBOZZ	5360-00-839-5600	59242	29201	SPRING, HELICAL CARBURETOR	EA	1
18	15	PAFZZ	5305-00-283-1913	80575	29201	SCREW, MACHINE PLATE MOUNTING	EA	1
18	16	XBOZZ		A59299	29201	PLATE CARBURETOR.....	EA	1
18	17	PAFZZ	5305-00-993-0191	MS35206-212	96906	SCREW, MACHINE	EA	1
18	18	XBFZZ		A59301A	29201	VANE ASSEMBLY GOVERNOR.....	EA	1
18	19	XBFZZ		59260	29201	LINK AIR VANE.....	EA	1
					41			

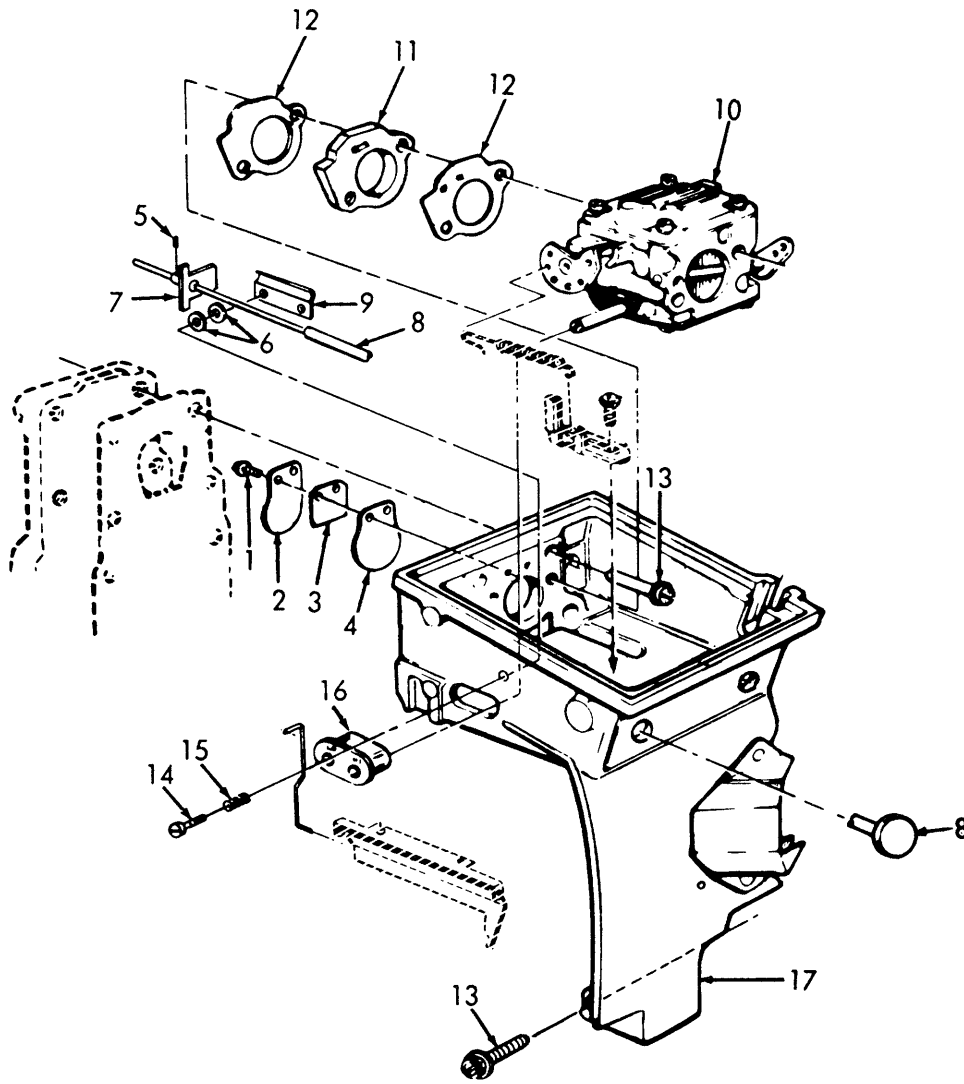

TS 3740-211-24P/19

Figure 19. Engine Carburetor Chamber

SECTION II

TM 5-3740-211-24P

(1) ILLUSTRATION		(2)	(3)	(4)	(5)	(6)	(7)	(8)
(a) FIG NO.	(b) ITEM NO.	SMR CODE	NATIONAL STOCK NUMBER	PART NUMBER	FSCM	DESCRIPTION USABLE ON CODE	U/M	QTY INC IN UNIT
19	1	XBFZZ	5305-00-993-0191	MS35206-212	96906	SCREW, MACHINE	EA	2
19	2	XBFZZ		58776	29201	STOP, REED CHAMBER.....	EA	1
19	3	XBFZZ		59053	29201	REED, BACK-UP CHAMBER	EA	1
19	4	XBFZZ		58775	29201	REED, VALVE CHAMBER	EA	1
19	5	PAOZZ	5305-00-717-6950	MS51963-9	96906	SETSCREW	EA	1
19	6	PAOZZ	5310-00-515-8058	AN960-8	88044	WASHER, FLAT	EA	2
19	7	XBOZZ		A59285	29201	COLLAR THROTTLE ROD	EA	1
19	8	XBOZZ		A62935	29201	ROD ASSEMBLY CARBURETOR.....	EA	1
19	9	XBOZZ		59367	29201	CLAMP THROTTLE ROD	EA	1
19	10	PAFZZ	2910-00-177-7768	A59535B	29201	CARBURETOR.....	EA	1
19	11	XBFZZ	2805-00-978-7306	58780	29201	SPACER CARBURETOR.....	EA	1
19	12	PAFZZ	5330-00-977-1005	58537A	29201	GASKET CARBURETOR.....	EA	2
19	13	XBFZZ		80891	29201	SCREW, MACHINE	EA	2
19	14	XBFZZ		80577	29201	SCREW, MACHINE	EA	2
19	15	PAOZZ	5360-00-307-1423	75892	29201	SPRING, HELICAL CARBURETOR	EA	2
19	16	XBOZZ		59058	29201	GROMMET CARBURETOR CHAMBER.....	EA	1
19	17	XBFZZ		A59607	29201	CHAMBER, CARBURETOR.....	EA	1
					43			

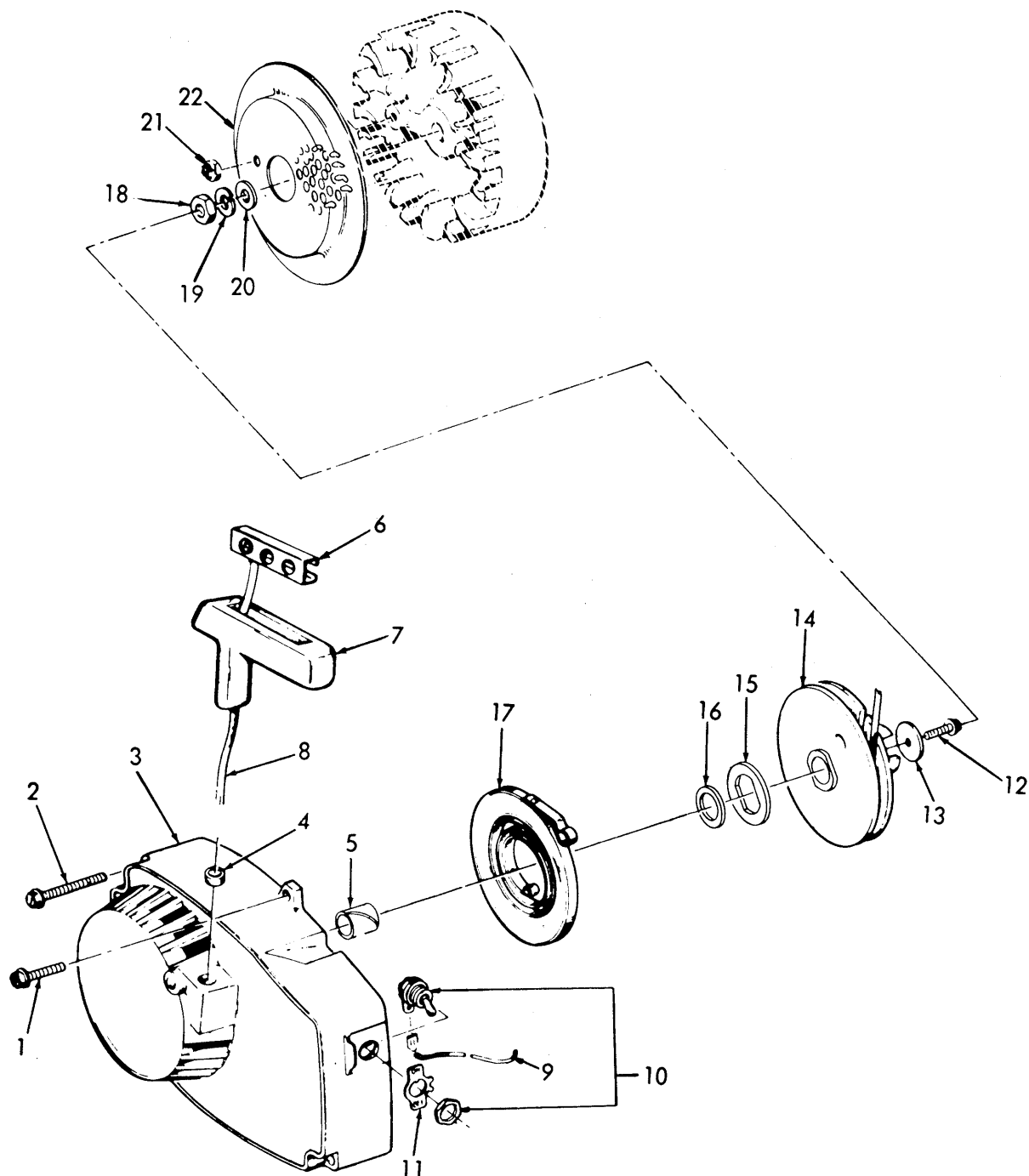

TS 3740-211-24P/20

Figure 20. Liquid Loading System Fan Housing

SECTION II

TM 5-3740-211-24P

(1) ILLUSTRATION		(2)	(3)	(4)	(5)	(6)	(7)	(8)
(a) FIG NO.	(b) ITEM NO.	SMR CODE	NATIONAL STOCK NUMBER	PART NUMBER	FSCM	DESCRIPTION USABLE ON CODE	U/M	QTY INC IN UNIT
						GROUP 12 - LIQUID LOADING SYSTEM PUMP STARTER FAN HOUSING AND IGNITION PARTS		
20	1	PAOZZ	5305-00-410-9335	80676	29201	SCREW, MACHINE	EA	4
20	2	PAOZZ	5305-00-935-7526	58963	29201	SCREW, MACHINE	EA	3
20	3	XBOZZ		A64516	29201	HOUSING, FAN.....	EA	1
20	4	XAOZZ		67177	29201	.BUSHING PUMP COVER.....	EA	1
20	5	XAOZZ		64443	29201	.BUSHING STARTER POST.....	EA	1
20	6	XBOZZ		58847	29201	INSERT, HANDLE STARTER	EA	1
20	7	PAOZZ	2990-00-977-1004	58915	29201	GRIP, HOPE STARTER.....	EA	1
20	8	PAOZZ	2990-00-978-7302	58806	29201	ROPE, STARTING.....	EA	1
20	9	PAOZZ	9525-00-985-3597	A59031	29201	LEAD GROUND W/TERMINALS	EA	1
20	10	PAOZZ	5930-00-988-7260	A57650-3	29201	SWITCH, TOGGLE W/NUT	EA	1
20	11	XBOZZ		72085A	29201	PLATE ON-OFF.....	EA	1
20	12	XBOZZ		80648	29201	SCREW, MACHINE	EA	1
20	13	XBOZZ		58763	29201	WASHER RETAINING.....	EA	1
20	14	PAOZZ	2990-00-177-7772	A64446	29201	PULLEY, STARTER.....	EA	1
20	15	XBOZZ		64049A	29201	.LOCK, SPRING STARTER	EA	1
20	16	XBOZZ		64400	29201	.BUSHING SPRING LOCK	EA	1
20	17	PAOZZ	5340-00-178-1368	58764A	29201	SPRING, RECOIL STARTER.....	EA	1
20	18	XBOZZ		81117	29201	NUT, PLAIN, HEXAGON.....	EA	1
20	19	PAOZZ	5310-00-829-3940	83002	29201	WASHER, LOCK	EA	1
20	20	PAOZZ	5310-00-829-3976	84056	29201	WASHE, FLAT.....	EA	1
20	21	PAOZZ	5310-00-254-4331	81109-2	29201	NUT, PLAIN, HEXAGON.....	EA	1
20	22	XBOZZ		58765	29201	SCREEN STARTER.....	EA	1
					45			

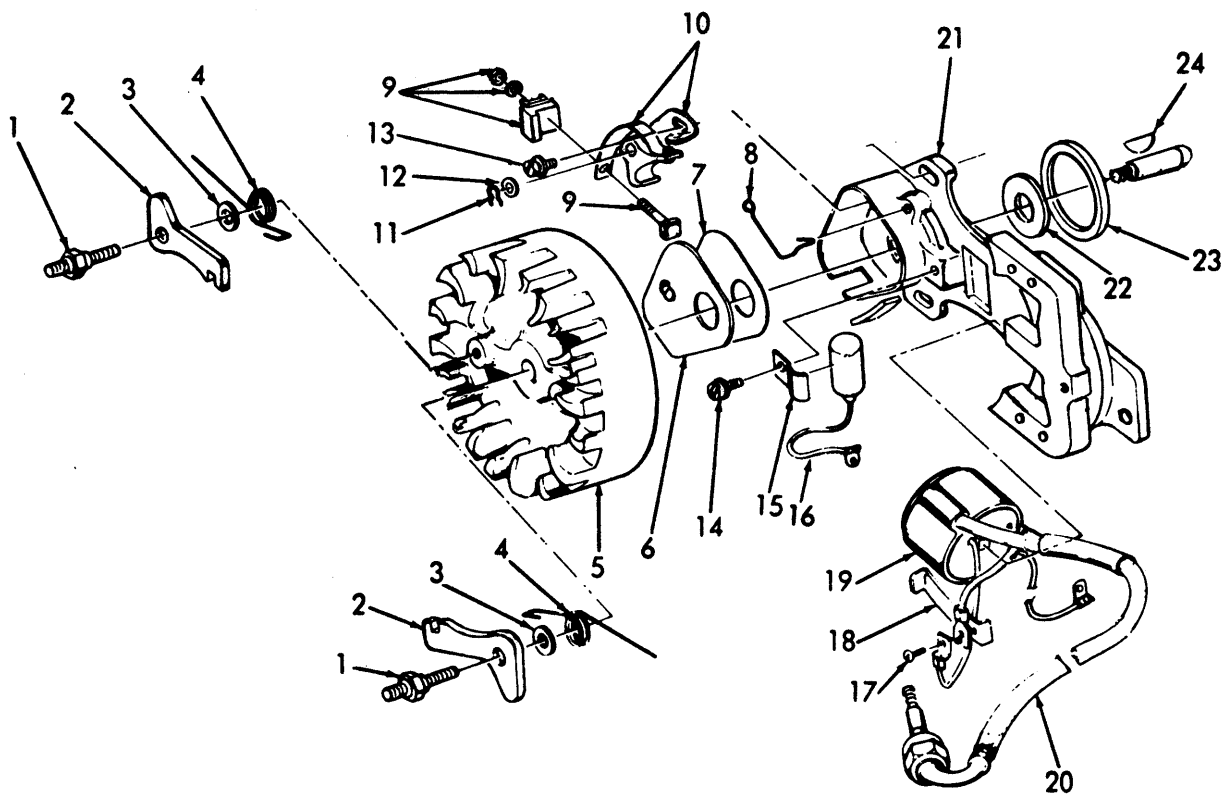

TS 3740-211-24P/21

Figure 21. Liquid Loading System Pump Starter and Ignition Parts.

SECTION II

TM 5-3740-211-24P

(1) ILLUSTRATION		(2)	(3)	(4)	(5)	(6)	(7)	(8)
(a) FIG NO.	(b) ITEM NO.	SMR CODE	NATIONAL STOCK NUMBER	PART NUMBER	FSCM	DESCRIPTION USABLE ON CODE	U/M	QTY INC IN UNIT
21	1	XBFZZ		58757B	29201	STUD PAWL	EA	2
21	2	XBFZZ	2990-00-177-7773	58756	29201	PAWL STARTER.....	EA	2
21	3	XBOZZ		58851	29201	WASHER, FLAT PAWL	EA	2
21	4	PAFZZ	5360-00-937-5358	58758	29201	SPRING STARTER PAWL.....	EA	2
21	5	XBFZZ	2920-00-177-7769	58809	29201	ROTOR MAGNETO.....	EA	1
21	6	XBFZZ		58811	29201	COVER BREAKER	EA	1
21	7	XBFZZ		58810	29201	GASKET COVER.....	EA	1
21	8	XBFZZ		76413	29201	SPRING COVER	EA	1
21	9	XBFZZ		A58934	29201	TERMINAL BLOCK.....	EA	1
21	10	PAFZZ	2920-00-979-6475	A58914	29201	POINT SET W/FELT.....	EA	1
21	11	XAFZZ		28008	29201	.CLIP POINT PIVOT POST.....	EA	1
21	12	XAFZZ		28028	29201	.WASHER POINT	EA	1
21	13	XBFZZ		76421	29201	SCREW POINTS MOUNTING	EA	1
21	14	PAFZZ	5305-00-281-8308	30261	29201	SCREW CONDENSER	EA	1
21	15	XBFZZ		59622	29201	CLAMP CONDENSER	EA	1
21	16	PAFZZ	2920-00-177-7770	63250	29201	CONDENSER.....	EA	1
21	17	XBFZZ		58872	29201	SCREW COIL GROUND	EA	1
21	18	XBFZZ		63726	29201	CLIP COIL RETAINING	EA	1
21	19	XBFZZ		58874	29201	COIL, IGNITION MAGNETO.....	EA	1
21	20	PAFZZ	2920-00-977-1118	54408	29201	LEAD HI-TENSION.....	EA	1
21	21	XBFZZ		58875A	29201	BOX, BREAKER POINTS	EA	1
21	22	XBFZZ		59760	29201	SEAL FELT.....	EA	1
21	23	PAFZZ	5330-00-852-5030	59538	29201	GASKET BREAKER BOX	EA	1
21	24	XBFZZ		75078	29201	KEY, WOODRUFF ROTOR.....	EA	1
					47			

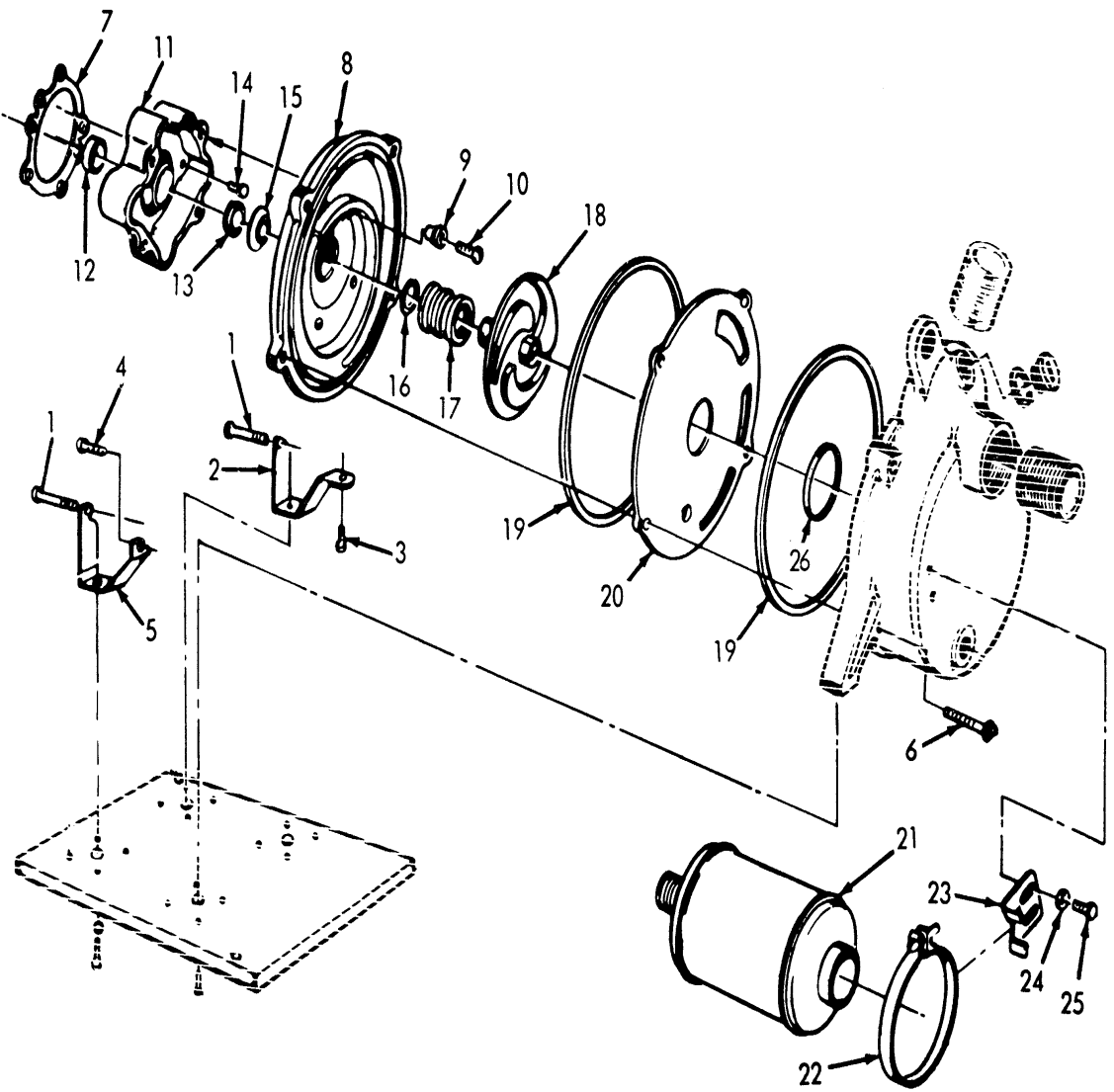
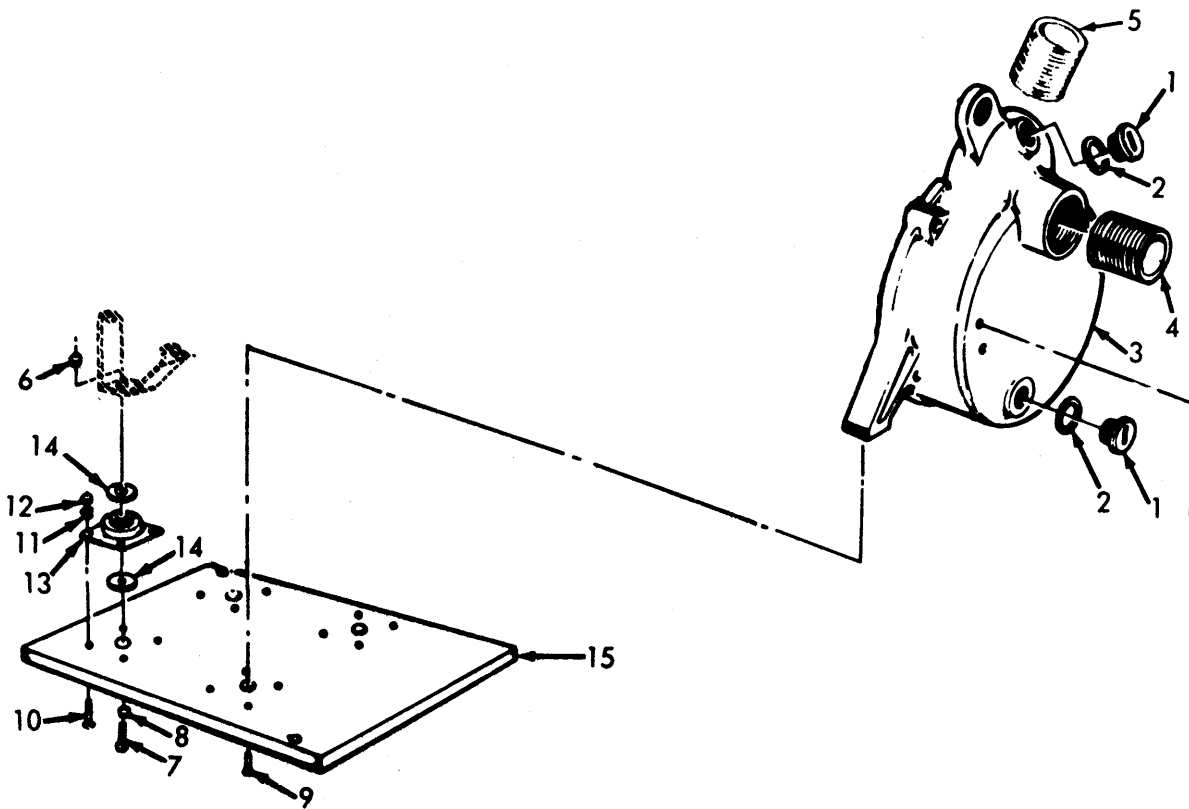

Figure 22. Liquid Loading System Pump.

(1) ILLUSTRATION		(2)	(3)	(4)	(5)	(6)	(7)	(8)
(a) FIG NO.	(b) ITEM NO.	SMR CODE	NATIONAL STOCK NUMBER	PART NUMBER	FSCM	DESCRIPTION USABLE ON CODE	U/M	QTY INC IN UNIT
						GROUP 13 - LIQUID LOADING SYSTEM PUMP		
22	1	PAOZZ	5305-00-935-7526	58963	29201	SCREW, MACHINE	EA	2
22	2	XBOZZ		59196-2	29201	LEG LH	EA	1
22	3	PAOZZ	5305-00-283-4712	80821	29201	SCREW, MACHINE LEG MOUNTING	EA	1
22	4	XBOZZ		80891	29201	SCREW, MACHINE	EA	1
22	5	XBOZZ		59195-2	29201	LEG RH.....	EA	1
22	6	PAOZZ	5305-00-071-2509	MS90728-12	96906	SCREW, MACHINE	EA	4
22	7	PAOZZ	5330-00-981-8749	63355	29201	GASKET PUMP.....	EA	1
22	8	XBFZZ	4320-00-168-2094	58661-2	29201	HOUSING, IMPELLER PUMP.....	EA	1
22	9	PAFZZ	5310-00-797-4065	62717	29201	WASHER, SEALING HOUSING MOUNTING	EA	4
22	10	PAFZZ	5305-00-283-1914	80916	29201	SCREW, MACHINE HOUSING MOUNTING .	EA	4
22	11	XBFZZ		A59547	29201	HOUSING, PUMP.....	EA	1
22	12	PAFZZ	3110-00-227-4796	58956	29201	BEARING PUMP	EA	1
22	13	PAFZZ	5330-00-852-5034	58688A	29201	SEAL PUMP	EA	1
22	14	PAFZZ	5305-00-410-9337	80899	29201	SCREW, MACHINE	EA	5
22	15	PAFZZ	4320-00-168-2095	62692	29201	SLINGER PUMP.....	EA	1
22	16	PAFZZ	5365-00-178-1367	62695	29201	SHIM	EA	V
22	16	PAFZZ	5365-00-178-1366	62696	29201	SHIM	EA	V
22	17	PAFZZ	5330-00-179-6249	A54575	29201	SEAL ASSEMBLY, VITON PUMP	EA	1
22	18	PAFZZ	4320-00-168-2093	58718-2	29201	IMPELLER, PUMP.....	EA	1
22	19	PAFZZ	5330-00-179-6243	54183	29201	GASKET IMPELLER.....	EA	2
22	20	PAFZZ	4320-00-168-2098	62693-2	29201	PLATE, WEAR PUMP.....	EA	1
22	21	PAOZZ	2990-00-463-5519	59550-1	29201	MUFFLER PUMP	EA	1
22	22	XBOZZ		59549-1	29201	STRAP MUFFLER	EA	1
22	23	XBOZZ		62691-1	29201	BRACKET MUFFLER	EA	1
22	24	XBOZZ		83077-1	29201	WASHER, LOCK BRACKET MOUNTING	EA	2
22	25	PAOZZ	5305-00-071-2506	MS90728-3	96906	SCREW, MACHINE	EA	2
22	26	PAFZZ	5330-00-179-6244	54182	29201	GASKET.....	EA	1
					49			



TS 3740-211-24P/23

Figure 23. Liquid Loading System Pump

SECTION II

TM 5-3740-211-24P

(1) ILLUSTRATION		(2)	(3)	(4)	(5)	(6)	(7)	(8)
(a) FIG NO.	(b) ITEM NO.	SMR CODE	NATIONAL STOCK NUMBER	PART NUMBER	FSCM	DESCRIPTION USABLE ON CODE	U/M	QTY INC IN UNIT
23	1	XBOZZ	4320-00-168-2096	59594A	29201	CAP DRAIN AND FILLER	EA	2
23	2	PAFZZ	5330-00-179-6247	59910	29201	GASKET CAP.....	EA	2
23	3	XBFZZ		58619-2	29201	HOUSING, PUMP.....	EA	1
23	4	XBOZZ		54185-1	29201	NIPPLE SHORT	EA	1
23	5	XBOZZ		62707-1	29201	NIPPLE LONG.....	EA	1
23	6	PAOZZ	5310-00-905-0762	M851967-3	96906	NUT, PLAIN,HEXAGON.....	EA	2
23	7	XBOZZ		80259	29201	SCREW,MACHINE BASE MOUNTING	EA	2
23	8	XBOZZ		83009	29201	WASHER, LOCK	EA	4
23	9	PAOZZ	5305-00-283-1907	80271	29201	SCREW, MACHINE HOUSING MOUNTING .	EA	2
23	10	PAOZZ	5305-00-283-1908	80642	29201	SCREI, MACHINE VIBRIATON MOUNT	EA	16
23	11	XBOZZ		83046	29201	WIA8HR, LOCK.....	EA	16
23	12	PAOZZ	5310-00-934-9751	MS35650-302	96906	NUT, PLAIN, HEXAGON.....	EA	12
23	13	PAOZZ	5340-00-178-1365	54861	29201	MOUNT, VIBRATION.....	EA	4
23	14	XBOZZ		54862	29201	WASHER SNUBBING.....	EA	8
23	15	XBOZZ		54867-1	29201	BASE, PUMP.....	EA	1
					51			

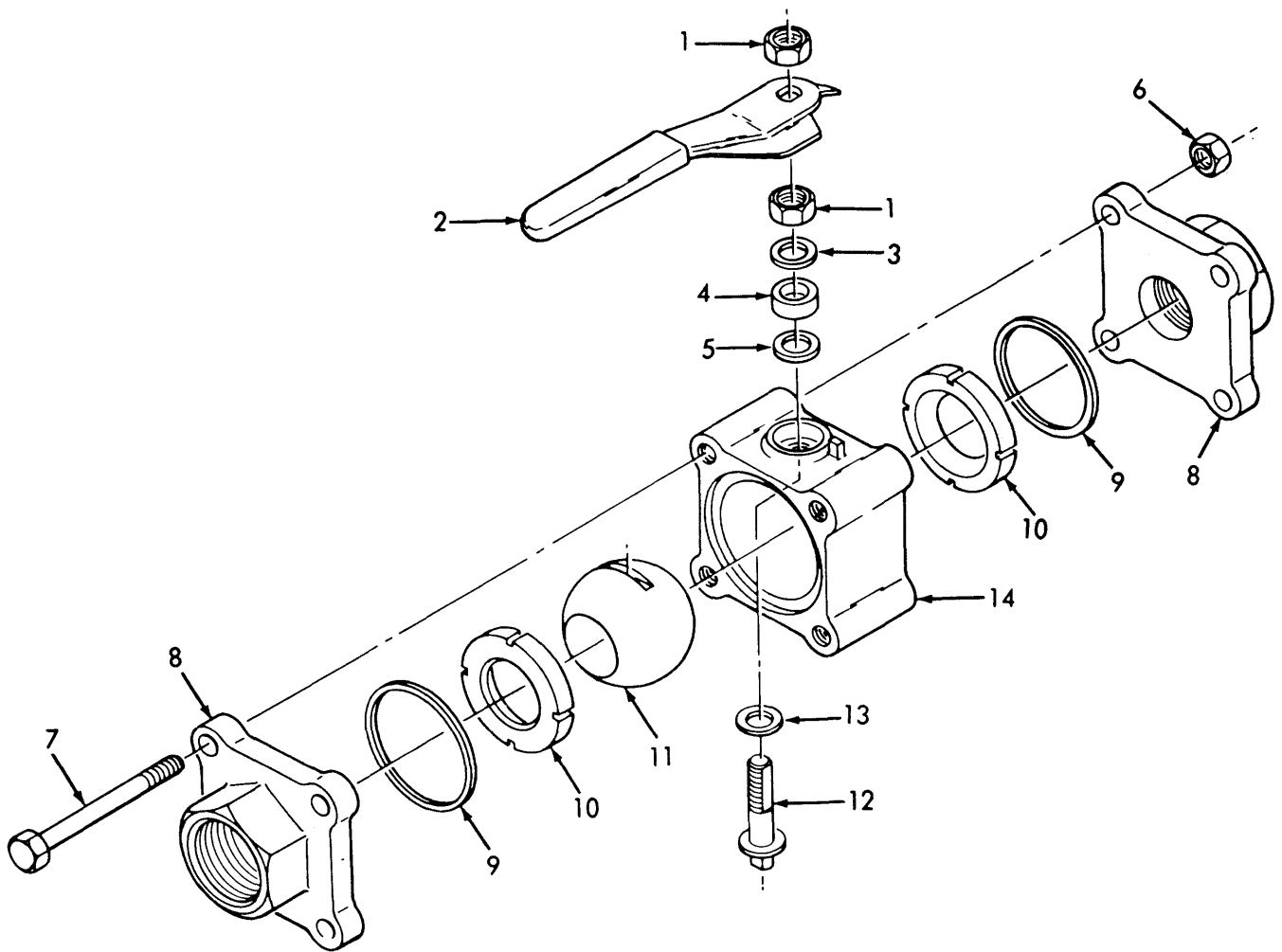

TS 3740-211-24P/24

Figure 24. Liquid Loading System Ball Valve.

SECTION II

TM 5-3740-211-24P

(1) ILLUSTRATION		(2)	(3)	(4)	(5)	(6)	(7)	(8)
(a) FIG NO.	(b) ITEM NO.	SMR CODE	NATIONAL STOCK NUMBER	PART NUMBER	FSCM	DESCRIPTION USABLE ON CODE	U/M	QTY INC IN UNIT
						GROUP 14 - LIQUID LOADING SYSTEM BALL VALVE		
24		XBOZZ		1-12-436TSE	98991	VALVE, BALL	EA	1
24	1	XBOZZ		1-12-436TSE11	98991	NUT, PLAIN, HEXAGON HANDLE.....	EA	2
24	2	XBOZZ		1-12-436TSE12	98991	HANDLE VALVE	EA	1
24	3	XBOZZ		1-12-436TSE10	98991	WASHER, FLAT VALVE	EA	1
24	4	XBOZZ		1-12-436TSE9	98991	FOLLOWER VALVE	EA	1
24	5	KFOZZ		1-12-436TSE7	98991	SEAL, STEM PART OF KIT P/N 1-1-2RX436TSE	EA	1
24	6	XBOZZ		1-12-436TSE14	98991	NUT, PLAIN, HEXAGON BODY	EA	4
24	7	XBOZZ		1-12-436TSE13	98991	BOLT, MACHINE BODY	EA	4
24	8	XBOZZ		1-12-436TSE2	98991	COVER, BODY VALVE	EA	2
24	9	KFOZZ		1-12-436TSE6	98991	SEAL, BODY SEE OH KIT, K436T-SE 1-1/2. PART OF KIT P/N.....	EA	1 EA 2
						1-1-2RK436TSE		
24	10	KFOZZ		1-12-436TSE5	98991	SEAT PART OF KIT P/N 1-1 2RK436TSE.....	EA	2
24	11	XBOZZ		1-12-436TSE3	98991	BALL VALVE	EA	1
24	12	XBOZZ		1-12-436TSE4	98991	STEM VALVE	EA	1
24	13	XBOZZ		1-12-436TSE8	98991	BEARING, THRUST VALVE	EA	1
24	14	XBOZZ		1-12-436TSE1	98991	BODY VALVE	EA	1
24		XBOZZ		1-1-2RK436TSE	98991	KIT, OVERHAUL VALVE	EA	1
24	5					SEAL, STEM	EA	1
24	9					SEAL, BODY	EA	2
24	10					SEAT.....	EA	2
					53			

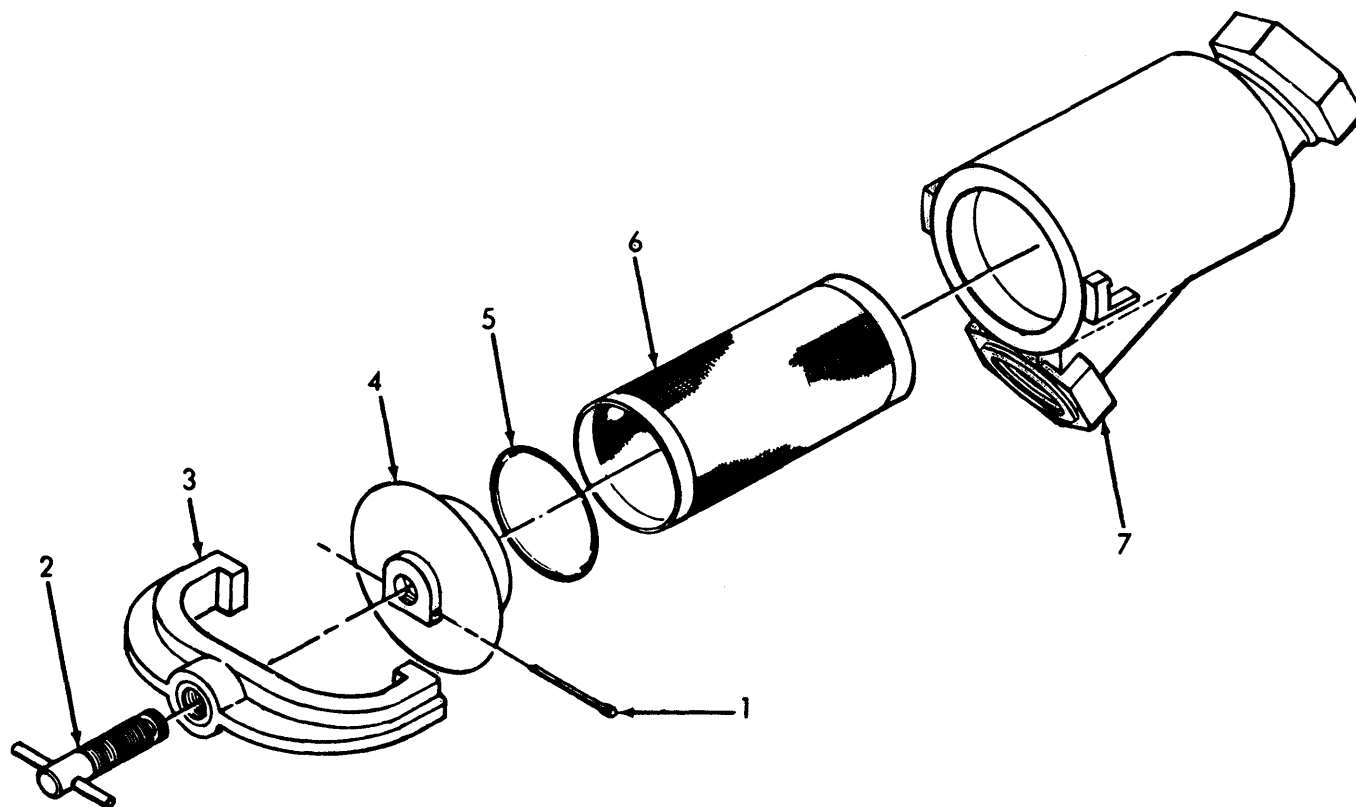

TS 3740-211-24P/25

Figure 25. Liquid Loading System Strainer.

SECTION II

TM 5-3740-211-24P

(1) ILLUSTRATION		(2)	(3)	(4)	(5)	(6)	(7)	(8)
(a) FIG NO.	(b) ITEM NO.	SMR CODE	NATIONAL STOCK NUMBER	PART NUMBER	FSCM	DESCRIPTION USABLE ON CODE	U/M	QTY INC IN UNIT
						GROUP 15 - LIQUID LOADING SYSTEM STRAINER		
25	1	XBOZZ		AN380-4-6	88044	PIN, COTTER STRAINER CAP.....	EA	1
25	2	XBOZZ		4108	22065	SCREW ASSEMBLY STRAINER	EA	1
25	3	XBOZZ		4171	22065	YOKE STRAINER	EA	1
25	4	XBOZZ		4168	22065	CAP STRAINER	EA	1
25	5	PAOZZ	5330-00-054-6865	4139	22065	PACKING, PREFORMED STRAINER CAP ...	EA	1
25	6	XBOZZ		4163	22065	SCREEN, 30 MESH STRAINER.....	EA	1
25	7	XBOZZ		4165	22065	BODY, HOSE STRAINER	EA	1
					55			

PART NUMBER	FSCM	FIG. NO.	ITEM NO.	PART NUMBER	FSCM	FIG. NO.	ITEM NO.
4123	22065	3	13	59642	29201	16	20
4139	22065	25	5	59644-1	29201	16	19
4163	22065	25	6	59760	29201	21	22
4164P30G	22065	15	12	59910	29201	23	2
4165	22065	25	7	6008-13	22065	5	9
4168	22065	25	4	6008-15	22065	5	8
4171	22065	25	3	6008-17	22065	5	7
4218-24	98441	15	9	6008-3	22065	5	14
432-1153-000	13499	14	19	6011	22065	1	8
4618ALEF	82247	13	6	6203	22065	9	15
4620V1	82247	13	4	6227TEF	82247	13	7
4624ALEF	82247	13	2	622706	22065	7	23
5053AL100MESH	82247	13	8	62691-1	29201	22	23
5053AL50MESH	82247	13	8	62692	29201	22	15
5160-66	22065	8	1	62693-2	29201	22	20
5160-66	22065	9	14	62695	29201	22	16
54182	29201	22	26	62696	29201	22	16
54183	29201	22	19	62707-1	29201	23	5
54185-1	29201	23	4	62717	29201	22	9
54408	29201	21	20	6300T5	22065	8	15
54576S	29201	17	9	6301	22065	9	17
54861	29201	23	13	6302	22065	9	12
54862	29201	23	14	6303-3	22065	9	19
54867-1	29201	23	15	6305	22065	9	16
55871	29201	17	4	6306	22065	9	7
56607	29201	16	5	6308T	22065	9	10
57289-1	29201	18	10	63250	29201	21	16
58319A	29201	18	4	6330-1	22065	1	21
58362	29201	18	11	63355	29201	22	7
58392-1	29201	18	5	63407	29201	16	2
58513	29201	17	7	63497-1	29201	17	13
58519	29201	16	18	63589	29201	18	3
58537A	29201	19	12	6370	22065	8	5
58619-2	29201	23	3	6370-1	22065	8	6
58661-2	29201	22	8	6370-11	22065	8	14
58668A	29201	17	2	6370-13	22065	8	8
58668A	29201	22	13	6370-15	22065	8	7
58706-4	29201	17	8	6370-17	22065	8	13
58718-2	29201	22	18	6370-19	22065	8	11
58724	29201	17	19	6370-21	22065	8	12
58725	29201	17	15	6370-3	22065	8	9
58726	29201	17	16	6371	22065	8	2
58732-4	29201	16	1	63726	29201	21	18
58756	29201	21	2	64049A	29201	20	15
58757B	29201	21	1	64400	29201	20	16
58758	29201	21	4	64443	29201	20	5
58763	29201	20	13	64813	29201	17	23
58764A	29201	20	17	6517	22065	7	11
58765	29201	20	22	6527	22065	7	13
58773-5	29201	18	2	65358	29201	16	9
58775	29201	19	4	6538-1	22065	7	8
58776	29201	19	2	6609	22065	9	11
58780	29201	19	11	6639	22065	9	3
58806	29201	20	8	6642	22065	9	4
58809	29201	21	5	6645	22065	1	17
58810	29201	21	7	6647	22065	10	9
58811	29201	21	6	6648	22065	10	5
58847	29201	20	6	6649-33	22065	10	8
58851	29201	21	3	6652	22065	10	7
58862	29201	16	17	6653	22065	10	6
58865	29201	16	16	6672	22065	10	2
58866	29201	16	14	6673	22065	10	1
58867	29201	16	13	6674	22065	10	4
58872	29201	21	17	67177	29201	20	4
58874	29201	21	19	7208	22065	7	4
58875A	29201	21	21	72085A	29201	20	11
58877	29201	17	24	7210	22065	7	20
58915	29201	20	7	7307	22065	7	18
58956	29201	17	3	7310	22065	7	21
58956	29201	22	12	7311	22065	7	19
58963	29201	20	2	7313	22065	7	24
58963	29201	22	1	7407	22065	2	14
59053	29201	19	3	7502-1	22065	7	26
59058	29201	19	16	75078	29201	17	14
59195-2	29201	22	5	75078	29201	21	24
59196-2	29201	22	2	7512	22065	7	22
59242	29201	18	14	75120	29201	17	22
59260	29201	18	19	7513	22065	7	15
59329	29201	18	9	7514	22065	7	16
59367	29201	19	9	7515	22065	7	17
59457	29201	16	15	7516	22065	7	14
59538	29201	21	23	7517	22065	7	9
59548-2	29201	17	12	7520-175427538	22065	2	15
59549-1	29201	22	22	7520-175696538-1	22065	2	18
59550-1	29201	22	21	7538	22065	7	10
59571	29201	16	7	7542	22065	7	12
59594A	29201	23	1	7550	22065	6	13
59622	29201	21	15	7569	22065	7	7

SECTION III. NATIONAL STOCK NUMBER AND PART NUMBER INDEX

PART NUMBER	FSCM	FIG. NO.	ITEM NO.	PART NUMBER	FSCM	FIG. NO.	ITEM NO.
75892	29201	19	15	80889	29201	17	20
76413	29201	21	8	80891	29201	19	13
76421	29201	21	13	80891	29201	22	4
8001SS	82247	13	10	80899	29201	22	14
80015SS	82247	13	10	80916	29201	22	10
8002SS	82247	13	10	81109	29201	16	11
8003SS	82247	13	10	81109-2	29201	20	21
8004SS	82247	13	10	81117	29201	20	18
80259	29201	23	7	83002	29201	20	19
80271	29201	23	9	83009	29201	17	6
80481	29201	18	6	83009	29201	23	8
80513	29201	16	6	83046	29201	18	7
80575	29201	18	15	83046	29201	23	11
80577	29201	19	14	83077-1	29201	22	24
80642	29201	23	10	8400-1-2	22065	3	12
80648	29201	20	12	8400-34	82247	12	15
80676	29201	20	1	84003-1	29201	16	12
80821	29201	22	3	84056	29201	20	20
80867	29201	17	11	86324	29201	18	12
				9758ASBALEF	82247	13	3

By Order of the Secretary of the Army:

E. C. MEYER
General, United States Army
Chief of Staff

Official:

J. C. PENNINGTON
Major General, United States Army
The Adjutant General

DISTRIBUTION:

To be distributed in accordance with DA Form 12-25A, .Insect and Pest Control.

*U.S. GOVERNMENT PRINTING OFFICE: 1979--665134/1456

RECOMMENDED CHANGES TO EQUIPMENT TECHNICAL PUBLICATIONS



THEN... JOT DOWN THE DOPE ABOUT IT ON THIS FORM, CAREFULLY TEAR IT OUT, FOLD IT AND DROP IT IN THE MAIL!

SOMETHING WRONG WITH THIS PUBLICATION?

FROM: (PRINT YOUR UNIT'S COMPLETE ADDRESS)

DATE SENT

PUBLICATION NUMBER

PUBLICATION DATE

PUBLICATION TITLE

BE EXACT... PIN-POINT WHERE IT IS

PAGE NO.

PARA-GRAPH

FIGURE NO.

TABLE NO.

IN THIS SPACE TELL WHAT IS WRONG AND WHAT SHOULD BE DONE ABOUT IT:

TEAR ALONG PERFORATED LINE

PRINTED NAME, GRADE OR TITLE, AND TELEPHONE NUMBER

SIGN HERE:

DA FORM 2028-2 JUL 79

PREVIOUS EDITIONS ARE OBSOLETE.

P.S.—IF YOUR OUTFIT WANTS TO KNOW ABOUT YOUR RECOMMENDATION MAKE A CARBON COPY OF THIS AND GIVE IT TO YOUR HEADQUARTERS.

The Metric System and Equivalents

Linear Measure

1 centimeter = 10 millimeters = .39 inch
 1 decimeter = 10 centimeters = 3.94 inches
 1 meter = 10 decimeters = 39.37 inches
 1 dekameter = 10 meters = 32.8 feet
 1 hectometer = 10 dekameters = 328.08 feet
 1 kilometer = 10 hectometers = 3,280.8 feet

Weights

1 centigram = 10 milligrams = .15 grain
 1 decigram = 10 centigrams = 1.54 grains
 1 gram = 10 decigrams = .035 ounce
 1 dekagram = 10 grams = .35 ounce
 1 hectogram = 10 dekagrams = 3.52 ounces
 1 kilogram = 10 hectograms = 2.2 pounds
 1 quintal = 100 kilograms = 220.46 pounds
 1 metric ton = 10 quintals = 1.1 short tons

Liquid Measure

1 centiliter = 10 milliliters = .34 fl. ounce
 1 deciliter = 10 centiliters = 3.38 fl. ounces
 1 liter = 10 deciliters = 33.81 fl. ounces
 1 dekaliter = 10 liters = 2.64 gallons
 1 hectoliter = 10 dekaliters = 26.42 gallons
 1 kiloliter = 10 hectoliters = 264.18 gallons

Square Measure

1 sq. centimeter = 100 sq. millimeters = .155 sq. inch
 1 sq. decimeter = 100 sq. centimeters = 15.5 sq. inches
 1 sq. meter (centare) = 100 sq. decimeters = 10.76 sq. feet
 1 sq. dekameter (are) = 100 sq. meters = 1,076.4 sq. feet
 1 sq. hectometer (hectare) = 100 sq. dekameters = 2.47 acres
 1 sq. kilometer = 100 sq. hectometers = .386 sq. mile

Cubic Measure

1 cu. centimeter = 1000 cu. millimeters = .06 cu. inch
 1 cu. decimeter = 1000 cu. centimeters = 61.02 cu. inches
 1 cu. meter = 1000 cu. decimeters = 35.31 cu. feet

Approximate Conversion Factors

To change	To	Multiply by	To change	To	Multiply by
inches	centimeters	2.540	ounce-inches	newton-meters	.007062
feet	meters	.305	centimeters	inches	.394
yards	meters	.914	meters	feet	3.280
miles	kilometers	1.609	meters	yards	1.094
square inches	square centimeters	6.451	kilometers	miles	.621
square feet	square meters	.093	square centimeters	square inches	.155
square yards	square meters	.836	square meters	square feet	10.764
square miles	square kilometers	2.590	square meters	square yards	1.196
acres	square hectometers	.405	square kilometers	square miles	.386
cubic feet	cubic meters	.028	square hectometers	acres	2.471
cubic yards	cubic meters	.765	cubic meters	cubic feet	35.315
fluid ounces	milliliters	29.573	cubic meters	cubic yards	1.308
pints	liters	.473	milliliters	fluid ounces	.034
quarts	liters	.946	liters	pints	2.113
gallons	liters	3.785	liters	quarts	1.057
ounces	grams	28.349	liters	gallons	.264
pounds	kilograms	.454	grams	ounces	.035
short tons	metric tons	.907	kilograms	pounds	2.205
pound-foot	newton-meters	1.356	metric tons	short tons	1.102
pound-inches	newton-meters	.11296			

Temperature (Exact)

°F	Fahrenheit temperature	5/9 (after subtracting 32)	Celsius temperature	°C
----	------------------------	----------------------------	---------------------	----

PIN: 005453-001